

Jerith Industrial

1" Picket | Heavy Duty | 



- 3** Panel Options
- 10** Post Options
- 15** Post Caps & Accessories
- 16** Custom Finishes
- 17** Construction Specification 32 31 19
- 20** Limited Lifetime Warranty
- 22** Swing Gates
- 37** Accent Gates
- 43** Rainbow Gates
- 49** Arched Estate Gates
- 52** Gate Hardware

Our Industrial Aluminum Fence provides attractive, maintenance-free security for industrial applications. It's the perfect choice whenever it's necessary to add safety and protection, yet complement the architectural or landscape design.

Jerith

ASSA ABLOY

Jerith Industrial

1" Picket | Heavy Duty

1" sq x .062" wall PICKETS | 1-5/8" x 1-5/8" (.100" side / .070" top) RAILS | 2-1/2" sq x .075" wall POSTS

STYLE OPTIONS

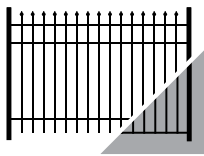

#101 (DB)

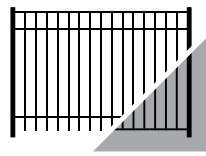

#202 (DB)

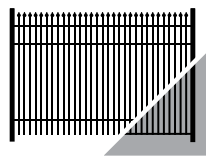

#401 (DB)

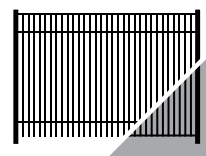

#402 (DB)

(DB): Drop Bottom

COLORS

- Black
- Bronze
- White



GATES

Gates match the fence style and are available in standard or arched designs.



QUALITY & STYLE

When we started manufacturing ornamental aluminum fences around 50 years ago, we made a commitment to producing only durable, high-quality, 100% American-made products. That commitment has become the backbone of our reputation and our promise to you.



LIFETIME LIMITED WARRANTY

Every fence comes with a lifetime warranty, made possible by our FencCoat™ finish and HS-35™ Aluminum Alloy.



DOMESTIC MANUFACTURING

Jerith is committed to providing products that are 100% extruded, coated, fabricated, assembled and packaged in the USA.

Jerith Industrial

PANEL OPTIONS

STANDARD & DROP BOTTOM OPTIONS AVAILABLE

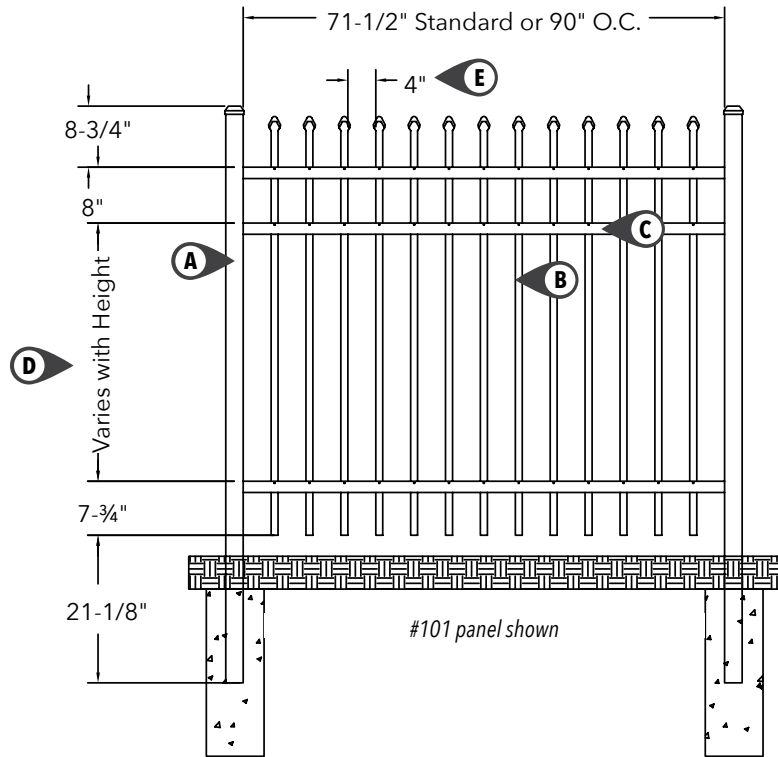

- Ⓐ 2-1/2" sq x .075" wall (standard) or .125" wall POSTS
- Ⓑ 1" sq x .062" wall PICKETS
- Ⓒ 1-5/8" x 1-5/8" (.100 side / .070" top) RAILS
- Ⓓ 4', 5', 6', 7' & 8' PANEL HEIGHTS
- Ⓔ 4" STANDARD OR 1-1/2" AIR SPACE

**Refer to construction specification
within this section for product details.**

Jerith Industrial

PANEL OPTIONS

STYLE #101 | 3-RAIL PANELS

STANDARD BOTTOM | 6' PANEL LENGTH (72" actual width) | 13 PICKETS PER PANEL | 20 PANELS PER PALLET

PANEL HEIGHT	ITEM NUMBER	WEIGHT	STOCKING
4'	IN48Ⓣ101SN	25 lbs	⊗
5'	IN60Ⓣ101SN	31 lbs	⊗
6'	IN72Ⓣ101SN	38 lbs	⊗

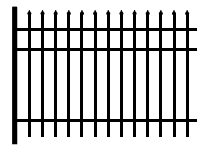

#101

STYLE #101 | 3-RAIL PANELS

DROP BOTTOM | 6' PANEL LENGTH (72" actual width) | 13 PICKETS PER PANEL | 20 PANELS PER PALLET

PANEL HEIGHT	ITEM NUMBER	WEIGHT	STOCKING
4'	IN48Ⓣ101SNDB	25 lbs	⊗
5'	IN60Ⓣ101SNDB	31 lbs	⊗
6'	IN72Ⓣ101SNDB	38 lbs	⊗

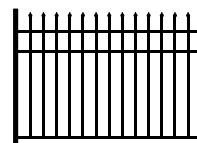

#101

STYLE #101 | 4-RAIL PANELS

STANDARD BOTTOM | 6' PANEL LENGTH (72" actual width) | 13 PICKETS PER PANEL | 20 PANELS PER PALLET

PANEL HEIGHT	ITEM NUMBER	WEIGHT	STOCKING
7'	IN84Ⓣ101SN	44 lbs	⊗
8'	IN96Ⓣ101SN	50 lbs	⊗

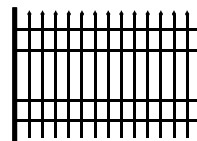

#101

STYLE #101 | 4-RAIL PANELS

DROP BOTTOM | 6' PANEL LENGTH (72" actual width) | 13 PICKETS PER PANEL | 20 PANELS PER PALLET

PANEL HEIGHT	ITEM NUMBER	WEIGHT	STOCKING
7'	IN84Ⓣ101SNDB	44 lbs	⊗
8'	IN96Ⓣ101SNDB	50 lbs	⊗

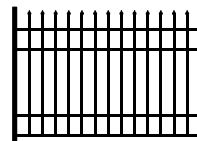

#101

Ⓣ = COLOR OPTIONS AVAILABLE | **B** = Black **Z** = Bronze **W** = White

⊗ = NON-STOCKED PRODUCT

For details, see Jerith's Sales Policy in the catalog guide.

NOTE: 4-rail is standard for 6' height, 3-rail is standard for all other heights

Jerith Industrial

PANEL OPTIONS

STYLE #101 | 3-RAIL PANELS

STANDARD BOTTOM | 7-1/2' PANEL LENGTH (90" actual width) | 17 PICKETS PER PANEL | 20 PANELS PER PALLET

PANEL HEIGHT	ITEM NUMBER	WEIGHT	STOCKING
4'	IL48Ⓞ101SN	32 lbs	Ⓞ
5'	IL60Ⓞ101SN	40 lbs	Ⓞ
6'	IL72Ⓞ101SN	48 lbs	Ⓞ

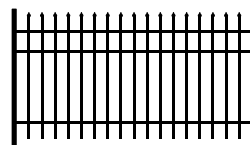

#101

STYLE #101 | 3-RAIL PANELS

DROP BOTTOM | 7-1/2' PANEL LENGTH (90" actual width) | 17 PICKETS PER PANEL | 20 PANELS PER PALLET

PANEL HEIGHT	ITEM NUMBER	WEIGHT	STOCKING
4'	IL48Ⓞ101SNDB	32 lbs	Ⓞ
5'	IL60Ⓞ101SNDB	40 lbs	Ⓞ
6'	IL72Ⓞ101SNDB	48 lbs	Ⓞ

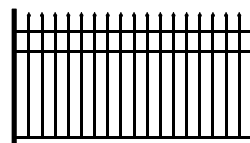

#101

STYLE #101 | 4-RAIL PANELS

STANDARD BOTTOM | 7-1/2' PANEL LENGTH (90" actual width) | 17 PICKETS PER PANEL | 20 PANELS PER PALLET

PANEL HEIGHT	ITEM NUMBER	WEIGHT	STOCKING
7'	IL84Ⓞ101SN	55 lbs	Ⓞ
8'	IL96Ⓞ101SN	63 lbs	Ⓞ

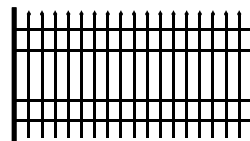

#101

STYLE #101 | 4-RAIL PANELS

DROP BOTTOM | 7-1/2' PANEL LENGTH (90" actual width) | 17 PICKETS PER PANEL | 20 PANELS PER PALLET

PANEL HEIGHT	ITEM NUMBER	WEIGHT	STOCKING
7'	IL84Ⓞ101SNDB	55 lbs	Ⓞ
8'	IL96Ⓞ101SNDB	63 lbs	Ⓞ

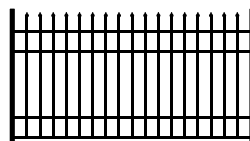

#101

Ⓞ = COLOR OPTIONS AVAILABLE | **B** = Black **Z** = Bronze **W** = White

Ⓞ = NON-STOCKED PRODUCT

For details, see Jerith's Sales Policy in the catalog guide.

NOTE: 4-rail is standard for 6' height, 3-rail is standard for all other heights

Jerith Industrial

PANEL OPTIONS

STYLE #202 | 3-RAIL PANELS

STANDARD BOTTOM | 6' PANEL LENGTH (72" actual width) | 13 PICKETS PER PANEL | 20 PANELS PER PALLET

PANEL HEIGHT	ITEM NUMBER	WEIGHT	STOCKING
4'	IN48Ⓞ202SN	25 lbs	Ⓞ
5'	IN60Ⓞ202SN	31 lbs	Ⓞ
6'	IN72Ⓞ202SN	38 lbs	Ⓞ

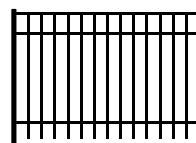

#202

STYLE #202 | 3-RAIL PANELS

DROP BOTTOM | 6' PANEL LENGTH (72" actual width) | 13 PICKETS PER PANEL | 20 PANELS PER PALLET

PANEL HEIGHT	ITEM NUMBER	WEIGHT	STOCKING
4'	IN48Ⓞ202SNDB	25 lbs	Ⓞ
5'	IN60Ⓞ202SNDB	31 lbs	Ⓞ
6'	IN72Ⓞ202SNDB	38 lbs	Ⓞ

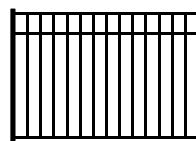

#202

STYLE #202 | 4-RAIL PANELS

STANDARD BOTTOM | 6' PANEL LENGTH (72" actual width) | 13 PICKETS PER PANEL | 20 PANELS PER PALLET

PANEL HEIGHT	ITEM NUMBER	WEIGHT	STOCKING
7'	IN84Ⓞ202SN	44 lbs	Ⓞ
8'	IN96Ⓞ202SN	50 lbs	Ⓞ

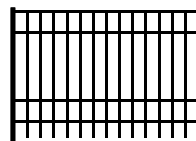

#202

STYLE #202 | 4-RAIL PANELS

DROP BOTTOM | 6' PANEL LENGTH (72" actual width) | 13 PICKETS PER PANEL | 20 PANELS PER PALLET

PANEL HEIGHT	ITEM NUMBER	WEIGHT	STOCKING
7'	IN84Ⓞ202SNDB	44 lbs	Ⓞ
8'	IN96Ⓞ202SNDB	50 lbs	Ⓞ

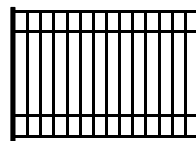

#202

Ⓞ = COLOR OPTIONS AVAILABLE | **B** = Black **Z** = Bronze **W** = White

Ⓞ = NON-STOCKED PRODUCT

For details, see Jerith's Sales Policy in the catalog guide.

NOTE: 4-rail is standard for 6' height, 3-rail is standard for all other heights

Jerith Industrial

PANEL OPTIONS

STYLE #202 | 3-RAIL PANELS

STANDARD BOTTOM | 7-1/2' PANEL LENGTH (90" actual width) | 17 PICKETS PER PANEL | 20 PANELS PER PALLET

PANEL HEIGHT	ITEM NUMBER	WEIGHT	STOCKING
4'	IL48@202SN	32 lbs	☉
5'	IL60@202SN	40 lbs	☉
6'	IL72@202SN	48 lbs	☉

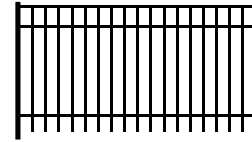

#202

STYLE #202 | 3-RAIL PANELS

DROP BOTTOM | 7-1/2' PANEL LENGTH (90" actual width) | 17 PICKETS PER PANEL | 20 PANELS PER PALLET

PANEL HEIGHT	ITEM NUMBER	WEIGHT	STOCKING
4'	IL48@202SNDB	32 lbs	☉
5'	IL60@202SNDB	40 lbs	☉
6'	IL72@202SNDB	48 lbs	☉

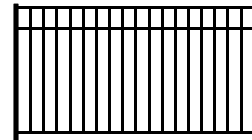

#202

STYLE #202 | 4-RAIL PANELS

STANDARD BOTTOM | 7-1/2' PANEL LENGTH (90" actual width) | 17 PICKETS PER PANEL | 20 PANELS PER PALLET

PANEL HEIGHT	ITEM NUMBER	WEIGHT	STOCKING
7'	IL84@202SN	55 lbs	☉
8'	IL96@202SN	63 lbs	☉

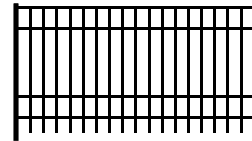

#202

STYLE #202 | 4-RAIL PANELS

DROP BOTTOM | 7-1/2' PANEL LENGTH (90" actual width) | 17 PICKETS PER PANEL | 20 PANELS PER PALLET

PANEL HEIGHT	ITEM NUMBER	WEIGHT	STOCKING
7'	IL84@202SNDB	55 lbs	☉
8'	IL96@202SNDB	63 lbs	☉

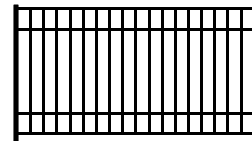

#202

☉ = COLOR OPTIONS AVAILABLE | **B** = Black **Z** = Bronze **W** = White

☉ = NON-STOCKED PRODUCT

For details, see Jerith's Sales Policy in the catalog guide.

NOTE: 4-rail is standard for 6' height, 3-rail is standard for all other heights

Jerith Industrial

PANEL OPTIONS

STYLE #401 | 3-RAIL PANELS

STANDARD BOTTOM | 6' PANEL LENGTH (72" actual width) | 27 PICKETS PER PANEL | 20 PANELS PER PALLET

PANEL HEIGHT	ITEM NUMBER	WEIGHT	STOCKING
4'	IN48Ⓞ401SN	32 lbs	Ⓞ
5'	IN60Ⓞ401SN	40 lbs	Ⓞ
6'	IN72Ⓞ401SN	52 lbs	Ⓞ

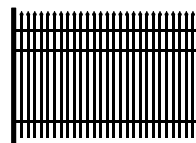

#401

STYLE #401 | 3-RAIL PANELS

DROP BOTTOM | 6' PANEL LENGTH (72" actual width) | 27 PICKETS PER PANEL | 20 PANELS PER PALLET

PANEL HEIGHT	ITEM NUMBER	WEIGHT	STOCKING
4'	IN48Ⓞ401SNDB	32 lbs	Ⓞ
5'	IN60Ⓞ401SNDB	40 lbs	Ⓞ
6'	IN72Ⓞ401SNDB	52 lbs	Ⓞ

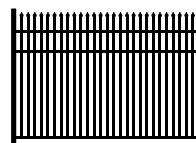

#401

STYLE #401 | 4-RAIL PANELS

STANDARD BOTTOM | 6' PANEL LENGTH (72" actual width) | 27 PICKETS PER PANEL | 20 PANELS PER PALLET

PANEL HEIGHT	ITEM NUMBER	WEIGHT	STOCKING
7'	IN84Ⓞ401SN	65 lbs	Ⓞ
8'	IN96Ⓞ401SN	74 lbs	Ⓞ

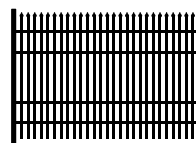

#401

STYLE #401 | 4-RAIL PANELS

DROP BOTTOM | 6' PANEL LENGTH (72" actual width) | 27 PICKETS PER PANEL | 20 PANELS PER PALLET

PANEL HEIGHT	ITEM NUMBER	WEIGHT	STOCKING
7'	IN84Ⓞ401SNDB	65 lbs	Ⓞ
8'	IN96Ⓞ401SNDB	74 lbs	Ⓞ

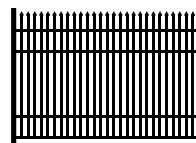

#401

Ⓞ = COLOR OPTIONS AVAILABLE | **B** = Black **Z** = Bronze **W** = White

Ⓞ = NON-STOCKED PRODUCT

For details, see Jerith's Sales Policy in the catalog guide.

NOTE: 4-rail is standard for 6' height, 3-rail is standard for all other heights

Jerith Industrial

PANEL OPTIONS

STYLE #402 | 3-RAIL PANELS

STANDARD BOTTOM | 6' PANEL LENGTH (72" actual width) | 27 PICKETS PER PANEL | 20 PANELS PER PALLET

PANEL HEIGHT	ITEM NUMBER	WEIGHT	STOCKING
4'	IN48Ⓞ402SN	32 lbs	Ⓞ
5'	IN60Ⓞ402SN	40 lbs	Ⓞ
6'	IN72Ⓞ402SN	52 lbs	Ⓞ

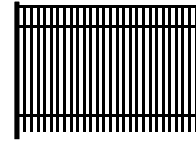

#402

STYLE #402 | 3-RAIL PANELS

DROP BOTTOM | 6' PANEL LENGTH (72" actual width) | 27 PICKETS PER PANEL | 20 PANELS PER PALLET

PANEL HEIGHT	ITEM NUMBER	WEIGHT	STOCKING
4'	IN48Ⓞ402SNDB	32 lbs	Ⓞ
5'	IN60Ⓞ402SNDB	40 lbs	Ⓞ
6'	IN72Ⓞ402SNDB	52 lbs	Ⓞ

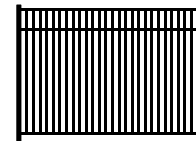

#402

STYLE #402 | 4-RAIL PANELS

STANDARD BOTTOM | 6' PANEL LENGTH (72" actual width) | 27 PICKETS PER PANEL | 20 PANELS PER PALLET

PANEL HEIGHT	ITEM NUMBER	WEIGHT	STOCKING
7'	IN84Ⓞ402SN	65 lbs	Ⓞ
8'	IN96Ⓞ402SN	74 lbs	Ⓞ

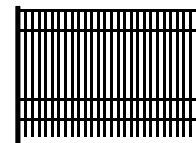

#402

STYLE #402 | 4-RAIL PANELS

DROP BOTTOM | 6' PANEL LENGTH (72" actual width) | 27 PICKETS PER PANEL | 20 PANELS PER PALLET

PANEL HEIGHT	ITEM NUMBER	WEIGHT	STOCKING
7'	IN84Ⓞ402SNDB	65 lbs	Ⓞ
8'	IN96Ⓞ402SNDB	74 lbs	Ⓞ

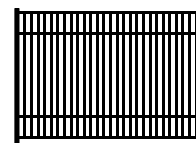

#402

Ⓞ = COLOR OPTIONS AVAILABLE | **B** = Black **Z** = Bronze **W** = White
 Ⓞ = NON-STOCKED PRODUCT

For details, see Jerith's Sales Policy in the catalog guide.

NOTE: 4-rail is standard for 6' height, 3-rail is standard for all other heights

Jerith Industrial

POST OPTIONS

STANDARD POSTS

AVAILABLE IN BOX QTY | SCREWS AND FLAT CAPS INCLUDED WITH EACH POST

2-1/2" POSTS x .075 WALL								
BOTTOM RAIL TREATMENT	RAIL	HEIGHT	STYLE	LENGTH	ITEM NUMBER	BOX QTY	BOX WEIGHT	
STANDARD	3 RAIL	4'	#101, #401	70"	KIN70⊗100◇P48	9	32 lbs	
			#202, #402	70"	KIN70⊗200◇P48	9	32 lbs	
		5'	#101, #401	82"	KIN82⊗100◇P60	9	36 lbs	
			#202, #402	82"	KIN82⊗200◇P60	9	36 lbs	
		6'	#101, #401	100"	KIN100⊗100◇P72	9	44 lbs	
			#202, #402	100"	KIN100⊗200◇P72	9	44 lbs	
	4 RAIL	7'	#101, #401	136"	KIN136⊗100◇P84	9	60 lbs	
			#202, #402	136"	KIN136⊗200◇P84	9	60 lbs	
		8'	#101, #401	136"	KIN136⊗100◇P96	9	60 lbs	
			#202, #402	136"	KIN136⊗200◇P96	9	60 lbs	
	DROP BOTTOM	3 RAIL	4'	#101, #401	70"	KIN70⊗100◇P48DB	9	32 lbs
				#202, #402	70"	KIN70⊗200◇P48DB	9	32 lbs
5'			#101, #401	82"	KIN82⊗100◇P60DB	9	36 lbs	
			#202, #402	82"	KIN82⊗200◇P60DB	9	36 lbs	
6'			#101, #401	100"	KIN100⊗100◇P72DB	9	44 lbs	
			#202, #402	100"	KIN100⊗200◇P72DB	9	44 lbs	
4 RAIL		7'	#101, #401	136"	KIN136⊗100◇P84DB	9	60 lbs	
			#202, #402	136"	KIN136⊗200◇P84DB	9	60 lbs	
		8'	#101, #401	136"	KIN136⊗100◇P96DB	9	60 lbs	
			#202, #402	136"	KIN136⊗200◇P96DB	9	60 lbs	

⊗ = COLOR OPTIONS AVAILABLE | **B** = Black **Z** = Bronze **W** = White

◇ = COLOR OPTIONS AVAILABLE | **L** = Line **C** = Corner **E** = End

NOTE: Screws and flat caps are included with the posts

Jerith Industrial

POST OPTIONS

STANDARD POSTS

AVAILABLE IN BOX QTY | SCREWS AND FLAT CAPS INCLUDED WITH EACH POST

2-1/2" GATE POSTS x .125 WALL									
BOTTOM RAIL TREATMENT	RAIL	HEIGHT	STYLE	LENGTH	ITEM NUMBER	BOX QTY	BOX WEIGHT		
STANDARD	3 RAIL	4'	#101, #401	70"	KIN70ⓧ100GP48	9	44 lbs		
			#202, #402	70"	KIN70ⓧ200GP48	9	44 lbs		
		5'	#101, #401	82"	KIN82ⓧ100GP60	9	48 lbs		
			#202, #402	82"	KIN82ⓧ200GP60	9	48 lbs		
		6'	#101, #401	100"	KIN100ⓧ100GP72	9	56 lbs		
			#202, #402	100"	KIN100ⓧ200GP72	9	56 lbs		
	4 RAIL	7'	#101, #401	136"	KIN136ⓧ100GP84	9	76 lbs		
			#202, #402	136"	KIN136ⓧ200GP84	9	76 lbs		
		8'	#101, #401	136"	KIN136ⓧ100GP96	9	76 lbs		
			#202, #402	136"	KIN136ⓧ200GP96	9	76 lbs		
		DROP BOTTOM	3 RAIL	4'	#101, #401	70"	KIN70ⓧ100GP48DB	9	44 lbs
					#202, #402	70"	KIN70ⓧ200GP48DB	9	44 lbs
5'	#101, #401			82"	KIN82ⓧ100GP60DB	9	48 lbs		
	#202, #402			82"	KIN82ⓧ200GP60DB	9	48 lbs		
6'	#101, #401			100"	KIN100ⓧ100GP72DB	9	56 lbs		
	#202, #402			100"	KIN100ⓧ200GP72DB	9	56 lbs		
4 RAIL	7'		#101, #401	136"	KIN136ⓧ100GP84DB	9	76 lbs		
			#202, #402	136"	KIN136ⓧ200GP84DB	9	76 lbs		
	8'		#101, #401	136"	KIN136ⓧ100GP96DB	9	76 lbs		
			#202, #402	136"	KIN136ⓧ200GP96DB	9	76 lbs		

ⓧ = COLOR OPTIONS AVAILABLE | **B** = Black **Z** = Bronze **W** = White

NOTE: Screws and flat caps are included with the posts

Jerith Industrial

POST OPTIONS

OPTIONAL POSTS

AVAILABLE IN BOX QTY | SCREWS AND FLAT CAPS INCLUDED WITH EACH POST

3" POSTS x .090 WALL									
BOTTOM RAIL TREATMENT	RAIL	HEIGHT	STYLE	LENGTH	ITEM NUMBER	BOX QTY	BOX WEIGHT		
STANDARD	3 RAIL	4'	#101, #401	70"	KCSIN70⊗100◇P48	4	54 lbs		
			#202, #402	70"	KCSIN70⊗200◇P48	4	54 lbs		
		5'	#101, #401	82"	KCSIN82⊗100◇P60	4	63 lbs		
			#202, #402	82"	KCSIN82⊗200◇P60	4	63 lbs		
		6'	#101, #401	100"	KCSIN100⊗100◇P72	4	81 lbs		
			#202, #402	100"	KCSIN100⊗200◇P72	4	81 lbs		
	4 RAIL	7'	#101, #401	136"	KCSIN136⊗100◇P84	4	117 lbs		
			#202, #402	136"	KCSIN136⊗200◇P84	4	117 lbs		
		8'	#101, #401	136"	KCSIN136⊗100◇P96	4	117 lbs		
			#202, #402	136"	KCSIN136⊗200◇P96	4	117 lbs		
		DROP BOTTOM	3 RAIL	4'	#101, #401	70"	KCSIN70⊗100◇P48DB	4	54 lbs
					#202, #402	70"	KCSIN70⊗200◇P48DB	4	54 lbs
5'	#101, #401			82"	KCSIN82⊗100◇P60DB	4	63 lbs		
	#202, #402			82"	KCSIN82⊗200◇P60DB	4	63 lbs		
6'	#101, #401			100"	KCSIN100⊗100◇P72DB	4	81 lbs		
	#202, #402			100"	KCSIN100⊗200◇P72DB	4	81 lbs		
4 RAIL	7'		#101, #401	136"	KCSIN136⊗100◇P84DB	4	117 lbs		
			#202, #402	136"	KCSIN136⊗200◇P84DB	4	117 lbs		
	8'		#101, #401	136"	KCSIN136⊗100◇P96DB	4	117 lbs		
			#202, #402	136"	KCSIN136⊗200◇P96DB	4	117 lbs		

⊗ = COLOR OPTIONS AVAILABLE | **B** = Black **Z** = Bronze **W** = White

◇ = COLOR OPTIONS AVAILABLE | **L** = Line **C** = Corner **E** = End

NOTE: Screws and flat caps are included with the posts

Jerith Industrial

POST OPTIONS

OPTIONAL POSTS

AVAILABLE IN BOX QTY | SCREWS AND FLAT CAPS INCLUDED WITH EACH POST

3" GATE POSTS x .125 WALL									
BOTTOM RAIL TREATMENT	RAIL	HEIGHT	STYLE	LENGTH	ITEM NUMBER	BOX QTY	BOX WEIGHT		
STANDARD	3 RAIL	4'	#101, #401	70"	KCSIN70ⓧ100GP48	4	81 lbs		
			#202, #402	70"	KCSIN70ⓧ200GP48	4	81 lbs		
		5'	#101, #401	82"	KCSIN82ⓧ100GP60	4	90 lbs		
			#202, #402	82"	KCSIN82ⓧ200GP60	4	90 lbs		
		6'	#101, #401	100"	KCSIN100ⓧ100GP72	4	108 lbs		
			#202, #402	100"	KCSIN100ⓧ200GP72	4	108 lbs		
	4 RAIL	7'	#101, #401	136"	KCSIN136ⓧ100GP84	4	153 lbs		
			#202, #402	136"	KCSIN136ⓧ200GP84	4	153 lbs		
		8'	#101, #401	136"	KCSIN136ⓧ100GP96	4	153 lbs		
			#202, #402	136"	KCSIN136ⓧ200GP96	4	153 lbs		
		DROP BOTTOM	3 RAIL	4'	#101, #401	70"	KCSIN70ⓧ100GP48DB	4	81 lbs
					#202, #402	70"	KCSIN70ⓧ200GP48DB	4	81 lbs
5'	#101, #401			82"	KCSIN82ⓧ100GP60DB	4	90 lbs		
	#202, #402			82"	KCSIN82ⓧ200GP60DB	4	90 lbs		
6'	#101, #401			100"	KCSIN100ⓧ100GP72DB	4	108 lbs		
	#202, #402			100"	KCSIN100ⓧ200GP72DB	4	108 lbs		
4 RAIL	7'		#101, #401	136"	KCSIN136ⓧ100GP84DB	4	153 lbs		
			#202, #402	136"	KCSIN136ⓧ200GP84DB	4	153 lbs		
	8'		#101, #401	136"	KCSIN136ⓧ100GP96DB	4	153 lbs		
			#202, #402	136"	KCSIN136ⓧ200GP96DB	4	153 lbs		

ⓧ = COLOR OPTIONS AVAILABLE | **B** = Black **Z** = Bronze **W** = White

NOTE: Screws and flat caps are included with the posts

Jerith Industrial

POST OPTIONS

OPTIONAL POSTS

AVAILABLE IN BOX QTY | SCREWS AND FLAT CAPS INCLUDED WITH EACH POST

4" BLANK POSTS x .125 WALL			
LENGTH	ITEM NUMBER	BOX QTY	BOX WEIGHT
84"	K84ⓧ4P	1	19 lbs
105"	K105ⓧ4P	1	24 lbs
144"	K144ⓧ4P	1	35 lbs

ⓧ = COLOR OPTIONS AVAILABLE | **B** = Black **Z** = Bronze **W** = White

NOTE: Screws and flat caps are included with the posts

Jerith Industrial

POST CAPS & ACCESSORIES

POST CAPS

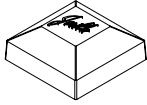

FLAT CAP
Aluminum

SIZE	ITEM NUMBER	WT. EACH
2-1/2" sq. x 2-1/2" sq.	⊗CP25PSJ	0.2 lbs
3" sq. x 3" sq.	⊗CP3PSJ	0.3 lbs
4" sq. x 4" sq.	⊗CP4PSJ	0.4 lbs
6" sq. x 6" sq.	⊗CP6PSJ	1.6 lbs

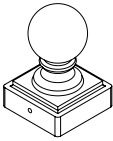

BALL CAP
Aluminum

2-1/2" sq. x 2-1/2" sq.	⊗BC25PSJ	0.6 lbs
4" sq. x 4" sq.	⊗BC4PSJ	1 lb

⊗ = COLOR OPTIONS AVAILABLE | B = Black Z = Bronze W = White

PANEL ACCESSORIES

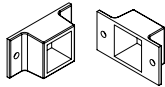

WALL MOUNT

1-5/8"	IN⊗WMC	1	0.22 lbs
--------	--------	---	----------



ADJUSTABLE WALL MOUNT

1-5/8"	IN⊗AWM	1	0.25 lbs
--------	--------	---	----------

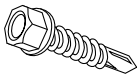

SELF DRILLING SCREW

#10 x 1-1/2"	⊗1015PSJ	6/18/27	0.009 lb
--------------	----------	---------	----------

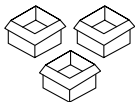

PICKET PLUG

1" sq.	PAPLUGS	100	1.5 lb
--------	---------	-----	--------

⊗ = COLOR OPTIONS AVAILABLE | B = Black Z = Bronze W = White

Jerith Industrial

CUSTOM FINISHES

CUSTOM FINISHES



TOUCH UP PAINT

.6 OZ.

ITEM NUMBER	QTY	WT. EACH
⊗BOT	1	0.6 oz



SPRAY PAINT

4.5 OZ.

⊗CAN	1	4.5 oz
------	---	--------

⊗ = COLOR OPTIONS AVAILABLE | **B** = Black **Z** = Bronze **W** = White

Jerith Industrial

CONSTRUCTION SPECIFICATION 32 31 19

ALUMINUM ORNAMENTAL FENCE SYSTEM

PART 1 - GENERAL

1.01 WORK INCLUDED

The contractor shall provide all labor, materials, and appurtenances necessary for installation of the industrial aluminum fence system defined herein at (specify project site).

1.02 RELATED WORK

Section ___ - Earthwork

Section ___ - Concrete

1.03 SYSTEM DESCRIPTION

The manufacturer shall supply a total fence system of Jerith Industrial® Aluminum, (for standard picket space, specify style #100, #101, #111, #200, #202; or for 1-5/8" picket spacing specify style #401, #402) design, (specify standard or drop) bottom rail treatment. The system shall include all components (i.e., panels, posts, gates, and hardware) required.

1.04 QUALITY ASSURANCE

The contractor shall provide laborers and supervisors who are thoroughly familiar with the type of construction involved and materials and techniques specified.

1.05 REFERENCES

- **ASTM B117** – Practice for Operating Salt Spray (Fog) Apparatus
- **ASTM B221** – Standard Specification for Aluminum and Aluminum-Alloy Extruded Bars, Rods, Wire, Profiles & Tubes
- **ASTM B85** – Standard Specification for Aluminum-Alloy Die Castings
- **ASTM D2247** – Standard Practice for Testing Water Resistance of Coatings in 100% Relative Humidity
- **ASTM F2957** – Specification for Ornamental Aluminum Fence Systems

1.06 SUBMITTAL

The manufacturer's submittal package including literature shall be submitted prior to installation to confirm compliance with all requirements for materials specified in this section.

1.07 PRODUCT HANDLING AND STORAGE

Upon receipt at the job site, all materials shall be checked to ensure that no damage occurred during shipping or handling. Materials shall be stored in such a manner to ensure proper ventilation and drainage, and to protect against damage, weather, vandalism, and theft.

1.08 PRODUCT WARRANTY

All fence components (i.e., rails, pickets, and posts) shall be warranted limited lifetime as specified within the product warranty document. Warranty shall cover any defects in workmanship and material finish including cracking, peeling, chipping, blistering, or corroding.

PART 2 - MATERIALS

2.01 MANUFACTURER

The manufacturer shall supply a total fence system of Jerith Industrial® Aluminum, (for standard picket space, specify style #100, #101, #111, #200, #202; or for 1-5/8" picket spacing specify style #401, #402) design, (specify standard or drop) bottom rail treatment, manufactured by Jerith Manufacturing LLC, Philadelphia, PA.

2.02 MATERIAL

- Material for fence framework (i.e., pickets, rails, and posts) shall be extruded from HS-35™ aluminum alloy conforming to the requirements of ASTM B221. Aluminum extrusions for posts and rails shall be alloy and temper designation 6005-T5 with a minimum yield strength of 35,000 psi. The aluminum extrusions for pickets shall be alloy and temper designation 6063-T5 with a minimum yield strength of 25,000 psi.
- Pickets shall be 1" square x .062" thick. Horizontal rails shall be 1-5/8" (.100" side wall) x 1-5/8" (.070" top wall) profile.

Jerith Industrial

CONSTRUCTION SPECIFICATION 32 31 19

- C. At every picket to rail intersection, pickets shall be affixed to rails using stainless steel fasteners. Rail to post connections shall be made using stainless steel screws with heads painted to match the color of the fence.
- D. Accessories: Aluminum castings shall be used for all post caps, scrolls, finials, and other miscellaneous hardware and conforming to the requirements of ASTM B85 for superior corrosion resistance. Hinges and latches shall be fabricated from aluminum, stainless steel, or composite materials.

2.03 FINISH

The manufactured fence system shall be subjected to the Jerith FencCoat™ coating process. This multi-phase coating process includes a three-stage pretreatment for uniform chemical conversion resulting in superior adhesion, followed by an electrostatic spray application of TGIC polyester powder for a cured minimum thickness of 2 mils (0.0508mm). The color shall be (specify Black, Bronze or White). The multi-layered powder coated fence system shall be capable of meeting the performance requirements for each quality characteristic shown in Table 2.

2.04 FABRICATION

- A. Horizontal rails shall be punched to accept pickets. There shall be a minimum 3 rails for each fence section. Pickets shall be pre-punched to accept rail to picket connection. Pickets shall be affixed to rails using stainless steel screws. Posts shall be pre-punched to accept fence section rails. Rails shall be affixed to post using manufacturer provided fasteners at every intersection. Die cast aluminum caps shall be provided with all posts. Fence posts and gate posts shall meet the minimum size requirements of Table 1.
- B. Gates shall be of welded construction with welds at every picket to rail intersection and rail to gate upright intersection. Gates shall be capable of supporting a 250 lb. vertical load without permanent deformation.
- C. Assembled sections shall be capable of supporting a 500 lb. vertical load at the midpoint of any horizontal rail without permanent deformation.
- D. Fence system shall meet minimum requirements within ASTM F2957.

PART 3 - EXECUTION

3.01 PREPARATION

All new installation shall be laid out by the contractor in accordance with the construction plans.

3.02 FENCE INSTALLATION

Fence posts shall be spaced according to Table 3. For installations that must be raked to follow sloping grades, the post spacing dimension must be measured along the grade. Fence panels rails shall be inserted into punched posts and affixed with fasteners. Posts shall be set in concrete footers per manufacturer's recommendation (Note: In some cases, local restrictions of freezing weather conditions may require a greater depth). The "Earthwork" and "Concrete" sections of this specification shall govern material requirements for the concrete footer. Posts setting by other methods such as plated posts or grouted core-drilled footers are permissible only if shown by engineering analysis to be sufficient in strength for the intended application.

3.03 FENCE INSTALLATION MAINTENANCE

When cutting/drilling rails or posts adhere to the following steps to seal the exposed surfaces; 1) Remove all metal shavings from cut area. 2) Apply custom finish paint matching fence color. Failure to seal exposed surfaces per steps 1 & 2 above will negate warranty. Spray cans or paint pens shall be used to finish exposed surfaces; it is recommended that paint pens be used to prevent overspray. Use of non-Jerith parts or components will negate the manufacturer's warranty.

3.04 GATE INSTALLATION

Gate posts shall be spaced according to the manufacturer's gate drawings, dependent on standard out-to-out gate leaf dimensions and gate hardware selected. Type and quantity of gate hinges shall be based on the application, weight, height, and number of gate cycles. The manufacturer's gate drawings shall identify the necessary gate hardware required for the application. Gate hardware shall be provided by the manufacturer of the gate and shall be installed per manufacturer's recommendations.

3.05 CLEANING

The contractor shall clean the jobsite of excess materials; post-hole excavations shall be scattered uniformly away from posts.

SEE REFERENCED TABLES ON THE FOLLOWING PAGE

Jerith Industrial

CONSTRUCTION SPECIFICATION 32 31 19

TABLE 1 | JERITH INDUSTRIAL | MINIMUM POST SIZE

FENCE HEIGHT	FENCE POSTS
UP TO 6' HEIGHT	2-1/2" X 2-1/2" X .075" ALUMINUM

GATE LEAF	GATE HEIGHT – UP TO & INCLUDING 6' HEIGHT
UP TO 6' WIDTH	2-1/2" X 2-1/2" X .125" ALUMINUM

TABLE 2 | JERITH INDUSTRIAL | COATING PERFORMANCE REQUIREMENTS

QUALITY CHARACTERISTICS	METHOD	PERFORMANCE REQUIREMENTS
HUMIDITY RESISTANCE	ASTM D2247	HUMIDITY RESISTANCE OVER 3000 HOURS
CORROSION RESISTANCE	ASTM B117	CORROSION RESISTANCE OVER 3000 HOURS

TABLE 2 | JERITH INDUSTRIAL | POST SPACING (PUNCHED POSTS)

STYLE	6' LENGTH PANELS	7-1/2' LENGTH PANELS
POST SETTINGS	71-1/2" ON CENTER	90" ON CENTER

Note: When using adjustable wall mount brackets on either or both ends of a fence section installation, care must be taken to ensure spacing between post and adjoining pickets meets applicable codes. This may require trimming one or both ends of the panel.

Jerith Industrial

LIMITED LIFETIME WARRANTY

ALUMINUM 1" PICKET FENCE

Jerith aluminum fence, posts, and swing gates are fabricated from the highest quality materials by skilled craftsmen to meet the highest standards of workmanship in the industry. Extruded aluminum fence system components shall be subjected to Jerith's FencCoat™ coating process, which includes a three-stage pretreatment wash followed by an electrostatic spray application of TGIC polyester powder coat finish, which provides the protection necessary to withstand adverse environmental conditions.

For Homeowners with the original proof of purchase, the powder-coated surfaces on all Jerith aluminum panels and posts are guaranteed under a Limited Lifetime Warranty for normal and proper usage without cause against cracking, peeling, chipping, blistering, or corroding. Normal and proper usage does not include physical damage or abrasion to the protective coating. Fences and Posts are guaranteed against defects in workmanship and materials during the guaranteed period. The warranty is non-transferable and is only valid to the original purchaser. Jerith Aluminum Fence is also guaranteed against defects in workmanship and materials.

The Limited Lifetime Warranty is replaced with a 30-year warranty for Commercial properties such as those owned by, and not limited to, corporations, governmental agencies, partnerships, schools, etc. The warranty on commercial properties is non-transferable.

Swing gates for Homeowners and Commercial properties, the powder-coated surfaces are guaranteed for 1-year for normal and proper usage without cause against cracking, peeling, chipping, blistering, or corroding. Material defects and workmanship are guaranteed for 1-year.

Should any aluminum fence panels, posts, or swing gates manufactured by Jerith Manufacturing fail in accordance with any of the above conditions, Jerith Manufacturing warrants to the original purchaser their redemption through replacement or renewal. The decision as to which method of redemption is allowed is solely at the discretion of Jerith.

Notice of failure under the conditions of this warranty shall be submitted via warranty claim form located at the following link (<https://bit.ly/JerithWarrantyClaim>). Form shall be submitted with all required information, original proof of purchase, description specifying the nature of defect and photographs of fence and site conditions. If contractor uses non Jerith parts/components this will negate warranty. Should the fence be improperly installed, Jerith Manufacturing shall not be responsible for guaranteed performance or appearance of the material. Neither does this guarantee apply when failure or damage is due to improper use or application, abuse or misuse, vandalism or acts of God. Jerith Manufacturing reserves the right to inspect the material to determine validity of the claim.

Upon validation of the claim by Jerith Manufacturing or its authorized representative, redemption by replacement or renewal shall be made by Jerith Manufacturing. Reimbursement for the cost of removal and installation of materials are not included in the guarantee, nor will Jerith provide those services.

The above constitutes the complete warranty by the manufacturer. No other agreement, written or implied, is valid. Jerith Manufacturing does not authorize any other person or agent to make any other express warranties. Jerith Manufacturing neither assumes nor authorizes any other person or agent to assume any other liability in connection with Jerith Aluminum Fence. Some jurisdictions do not allow limitations on how long an implied warranty lasts, nor do they allow an exclusion or limitation of incidental or consequential damages; therefore, the limitations and exclusions noted herein may not apply.

Jerith Industrial

SWING GATES

SINGLE SWING GATE SPECIFICATIONS

2" sq. x .125" wall GATE ENDS | 1-5/8" x 1-5/8" (.100" side/.070" top) RAILS | 1" sq. x .062" wall PICKETS

**SINGLE SWING
DIMENSIONAL DRAWING**

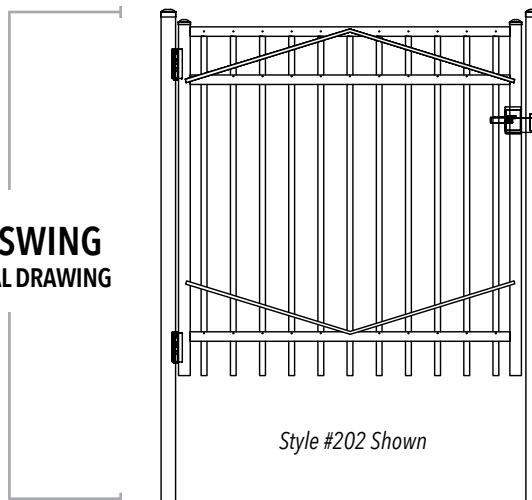

**SINGLE SWING
HARDWARE & POST
INTERSPACES**

OPENING	LEAF WIDTH*	HC	LC	P _S	HC	LC	P _S
3'	34-3/4"	1/2"	3/4"	36"	1/2"	3/4"	36"
4'	46-3/4"	1/2"	3/4"	48"	1/2"	3/4"	48"
5'	58-3/4"	1/2"	3/4"	60"	1/2"	3/4"	60"
6'	70-3/4"	1/2"	3/4"	72"	1/2"	3/4"	72"
7'	82-3/4"	1/2"	3/4"	84"	1/2"	3/4"	84"
8'	94-3/4"	1/2"	3/4"	96"	1/2"	3/4"	96"
9'	106-3/4"	1/2"	3/4"	108"	1/2"	3/4"	108"
10'	118-3/4"	1/2"	3/4"	120"	1/2"	3/4"	120"
11'	130-3/4"	1/2"	3/4"	132"	1/2"	3/4"	132"
12'	142-3/4"	1/2"	3/4"	144"	1/2"	3/4"	144"
13'	154-3/4"	1/2"	3/4"	156"	1/2"	3/4"	156"
14'	166-3/4"	1/2"	3/4"	168"	1/2"	3/4"	168"
15'	178-3/4"	1/2"	3/4"	180"	1/2"	3/4"	180"

W = width*
HC = hinge clearance

LC = latch clearance
P_S = gate post spacing**

** From inside to inside

Gate Hardware sold separately.
See Gate Hardware section for specific details.

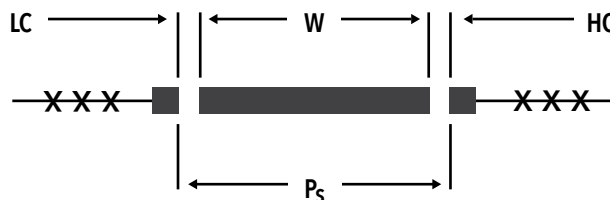

Jerith Industrial

SWING GATES

DOUBLE SWING GATE SPECIFICATIONS

2" sq. x .125" wall GATE ENDS | 1-5/8" x 1-5/8" (.100" side/.070" top) RAILS | 1" sq. x .062" wall PICKETS

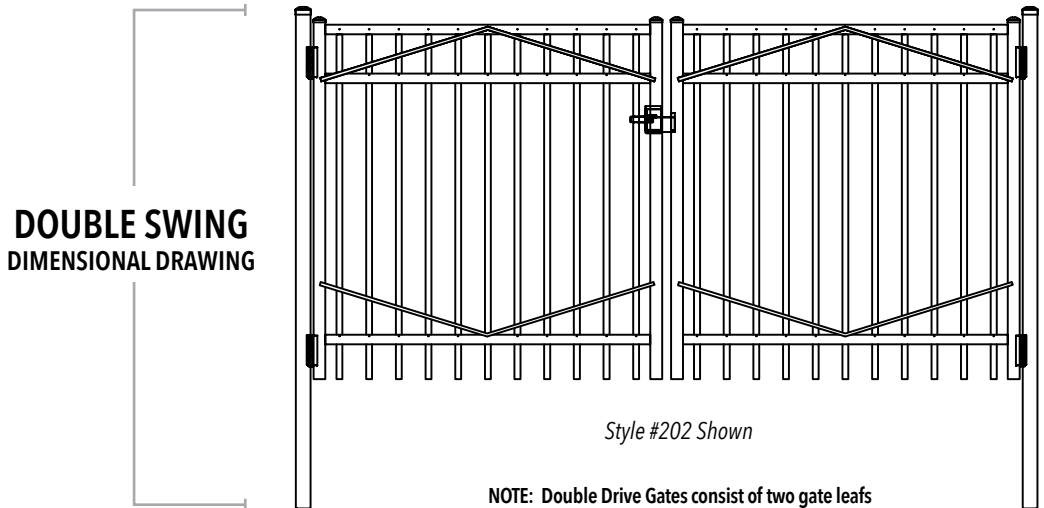

DOUBLE SWING HARDWARE & POST INTERSPACES

OPENING	LEAF WIDTH*	HC	LC	P _d
6'	70-3/4"	1/2"	3/4"	36"
8'	94-3/4"	1/2"	3/4"	48"
10'	118-3/4"	1/2"	3/4"	60"
12'	142-3/4"	1/2"	3/4"	144"
14'	166-3/4"	1/2"	3/4"	168"
16'	190-3/4"	1/2"	3/4"	192"
18'	214-3/4"	1/2"	3/4"	216"
20'	238-3/4"	1/2"	3/4"	240"
22'	262-3/4"	1/2"	3/4"	264"
24'	286-3/4"	1/2"	3/4"	288"
26'	310-3/4"	1/2"	3/4"	312"
28'	334-3/4"	1/2"	3/4"	336"
30'	358-3/4"	1/2"	3/4"	360"

W = width (x2)* LC = latch clearance
 HC = hinge clearance (x2) P_d = gate post spacing**

** From inside to inside

Gate Hardware sold separately.
 See Gate Hardware section for specific details.

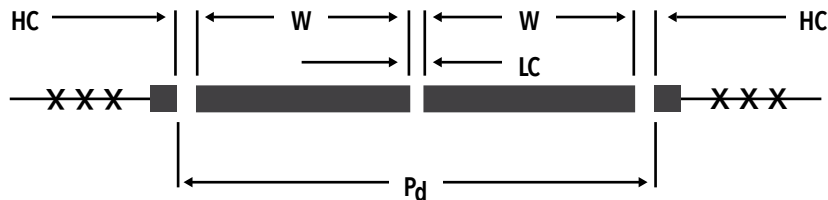

Jerith Industrial

SWING GATES

3-RAIL SINGLE SWING GATES

STANDARD BOTTOM | GATE HARDWARE SOLD SEPARATELY

OPENING	LEAF WIDTH	ITEM NUMBER	PICKET QTY	WEIGHT	STOCKING	
4' HEIGHT	3'	IN48⊗ ⊠36	6	21 lbs	⊙	
	4'	IN48⊗ ⊠48	8	28 lbs	⊙	
	5'	IN48⊗ ⊠60	11	33 lbs	⊙	
	6'	IN48⊗ ⊠72	13	38 lbs	⊙	
	7'	IN48⊗ ⊠84	16	44 lbs	⊙	
	8'	IN48⊗ ⊠96	16	49 lbs	⊙	
	9'	IN48⊗ ⊠108	18	55 lbs	⊙	
	10'	IN48⊗ ⊠120	22	61 lbs	⊙	
	11'	IN48⊗ ⊠132	24	67 lbs	⊙	
	12'	IN48⊗ ⊠144	26	74 lbs	⊙	
	13'	IN48⊗ ⊠156	28	80 lbs	⊙	
	14'	IN48⊗ ⊠168	30	85 lbs	⊙	
	15'	IN48⊗ ⊠180	32	91 lbs	⊙	
	5' HEIGHT	3'	IN60⊗ ⊠36	6	25 lbs	⊙
		4'	IN60⊗ ⊠48	8	32 lbs	⊙
5'		IN60⊗ ⊠60	11	37 lbs	⊙	
6'		IN60⊗ ⊠72	13	42 lbs	⊙	
7'		IN60⊗ ⊠84	15	48 lbs	⊙	
8'		IN60⊗ ⊠96	16	53 lbs	⊙	
9'		IN60⊗ ⊠108	18	59 lbs	⊙	
10'		IN60⊗ ⊠120	22	63 lbs	⊙	
11'		IN60⊗ ⊠132	24	71 lbs	⊙	
12'		IN60⊗ ⊠144	26	78 lbs	⊙	
13'		IN60⊗ ⊠156	28	84 lbs	⊙	
14'		IN60⊗ ⊠168	30	89 lbs	⊙	
15'		IN60⊗ ⊠180	32	95 lbs	⊙	

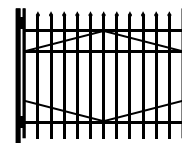

#101

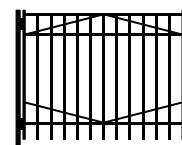

#202

⊗ = COLOR OPTIONS AVAILABLE | **B** = Black **Z** = Bronze **W** = White

⊠ = FENCE STYLES AVAILABLE | **101** = #101 **202** = #202

⊙ = NON-STOCKED PRODUCT

NOTE: Double Drive Gates consist of two gate leaves.
Gate leaf width greater than 60" will have a diagonal brace, not V brace.

Jerith Industrial

SWING GATES

3-RAIL SINGLE SWING GATES

STANDARD BOTTOM | GATE HARDWARE SOLD SEPARATELY

OPENING	LEAF WIDTH	ITEM NUMBER	PICKET QTY	WEIGHT	STOCKING
3'	34-3/4"	IN72⊗ ⊠36	6	30 lbs	⊙
4'	46-3/4"	IN72⊗ ⊠48	8	37 lbs	⊙
5'	58-3/4"	IN72⊗ ⊠60	11	44 lbs	⊙
6'	70-3/4"	IN72⊗ ⊠72	13	51 lbs	⊙
7'	82-3/4"	IN72⊗ ⊠84	15	58 lbs	⊙
8'	94-3/4"	IN72⊗ ⊠96	16	65 lbs	⊙
9'	106-3/4"	IN72⊗ ⊠108	18	72 lbs	⊙
10'	118-3/4"	IN72⊗ ⊠120	22	79 lbs	⊙
11'	130-3/4"	IN72⊗ ⊠132	24	86 lbs	⊙
12'	142-3/4"	IN72⊗ ⊠144	26	93 lbs	⊙
13'	154-3/4"	IN72⊗ ⊠156	28	100 lbs	⊙
14'	166-3/4"	IN72⊗ ⊠168	30	107 lbs	⊙
15'	178-3/4"	IN72⊗ ⊠180	32	114 lbs	⊙

6'
HEIGHT

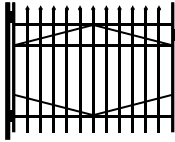

#101

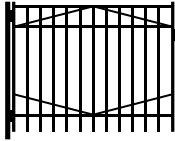

#202

⊗ = COLOR OPTIONS AVAILABLE | **B** = Black **Z** = Bronze **W** = White
 ⊠ = FENCE STYLES AVAILABLE | **101** = #101 **202** = #202
 ⊙ = NON-STOCKED PRODUCT

NOTE: Double Drive Gates consist of two gate leafs.
 Gate leaf width greater than 60" will have a diagonal brace, not V brace.

Jerith Industrial

SWING GATES

3-RAIL SINGLE SWING GATES

DROP BOTTOM | GATE HARDWARE SOLD SEPARATELY

OPENING	LEAF WIDTH	ITEM NUMBER	PICKET QTY	WEIGHT	STOCKING	
4' HEIGHT	3'	IN48⊗ <u>⊗</u> 36DB	6	21 lbs	⊙	
	4'	IN48⊗ <u>⊗</u> 48DB	8	28 lbs	⊙	
	5'	IN48⊗ <u>⊗</u> 60DB	11	33 lbs	⊙	
	6'	IN48⊗ <u>⊗</u> 72DB	13	38 lbs	⊙	
	7'	IN48⊗ <u>⊗</u> 84DB	16	44 lbs	⊙	
	8'	IN48⊗ <u>⊗</u> 96DB	16	49 lbs	⊙	
	9'	IN48⊗ <u>⊗</u> 108DB	18	55 lbs	⊙	
	10'	IN48⊗ <u>⊗</u> 120DB	22	61 lbs	⊙	
	11'	IN48⊗ <u>⊗</u> 132DB	24	67 lbs	⊙	
	12'	IN48⊗ <u>⊗</u> 144DB	26	74 lbs	⊙	
	13'	IN48⊗ <u>⊗</u> 156DB	28	80 lbs	⊙	
	14'	IN48⊗ <u>⊗</u> 168DB	30	85 lbs	⊙	
	15'	IN48⊗ <u>⊗</u> 180DB	32	91 lbs	⊙	
	5' HEIGHT	3'	IN60⊗ <u>⊗</u> 36DB	6	25 lbs	⊙
		4'	IN60⊗ <u>⊗</u> 48DB	8	32 lbs	⊙
5'		IN60⊗ <u>⊗</u> 60DB	11	37 lbs	⊙	
6'		IN60⊗ <u>⊗</u> 72DB	13	42 lbs	⊙	
7'		IN60⊗ <u>⊗</u> 84DB	15	48 lbs	⊙	
8'		IN60⊗ <u>⊗</u> 96DB	16	53 lbs	⊙	
9'		IN60⊗ <u>⊗</u> 108DB	18	59 lbs	⊙	
10'		IN60⊗ <u>⊗</u> 120DB	22	63 lbs	⊙	
11'		IN60⊗ <u>⊗</u> 132DB	24	71 lbs	⊙	
12'		IN60⊗ <u>⊗</u> 144DB	26	78 lbs	⊙	
13'		IN60⊗ <u>⊗</u> 156DB	28	84 lbs	⊙	
14'		IN60⊗ <u>⊗</u> 168DB	30	89 lbs	⊙	
15'		IN60⊗ <u>⊗</u> 180DB	32	95 lbs	⊙	

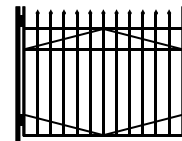

#101

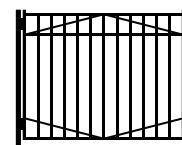

#202

⊗ = COLOR OPTIONS AVAILABLE | **B** = Black **Z** = Bronze **W** = White

⊗ = FENCE STYLES AVAILABLE | **101** = #101 **202** = #202

⊙ = NON-STOCKED PRODUCT

NOTE: Double Drive Gates consist of two gate leaves.
Gate leaf width greater than 60" will have a diagonal brace, not V brace.

Jerith Industrial

SWING GATES

3-RAIL SINGLE SWING GATES

DROP BOTTOM | GATE HARDWARE SOLD SEPARATELY

OPENING	LEAF WIDTH	ITEM NUMBER	PICKET QTY	WEIGHT	STOCKING
3'	34-3/4"	IN72⊗ ⊠36DB	6	30 lbs	⊙
4'	46-3/4"	IN72⊗ ⊠48DB	8	37 lbs	⊙
5'	58-3/4"	IN72⊗ ⊠60DB	11	44 lbs	⊙
6'	70-3/4"	IN72⊗ ⊠72DB	13	51 lbs	⊙
7'	82-3/4"	IN72⊗ ⊠84DB	15	58 lbs	⊙
8'	94-3/4"	IN72⊗ ⊠96DB	16	65 lbs	⊙
9'	106-3/4"	IN72⊗ ⊠108DB	18	72 lbs	⊙
10'	118-3/4"	IN72⊗ ⊠120DB	22	79 lbs	⊙
11'	130-3/4"	IN72⊗ ⊠132DB	24	86 lbs	⊙
12'	142-3/4"	IN72⊗ ⊠144DB	26	93 lbs	⊙
13'	154-3/4"	IN72⊗ ⊠156DB	28	100 lbs	⊙
14'	166-3/4"	IN72⊗ ⊠168DB	30	107 lbs	⊙
15'	178-3/4"	IN72⊗ ⊠180DB	32	114 lbs	⊙

6'
HEIGHT

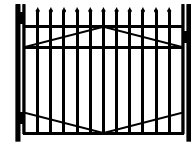

#101

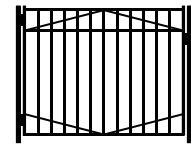

#202

⊗ = COLOR OPTIONS AVAILABLE | **B** = Black **Z** = Bronze **W** = White

⊠ = FENCE STYLES AVAILABLE | **101** = #101 **202** = #202

⊙ = NON-STOCKED PRODUCT

NOTE: Double Drive Gates consist of two gate leaves.
Gate leaf width greater than 60" will have a diagonal brace, not V brace.

Jerith Industrial

SWING GATES

3-RAIL SINGLE SWING GATES

STANDARD BOTTOM | GATE HARDWARE SOLD SEPARATELY

	OPENING	LEAF WIDTH	ITEM NUMBER	PICKET QTY	WEIGHT	STOCKING
4' HEIGHT	3'	34-3/4"	IN48⊗ ⊠36	12	28 lbs	⊙
	4'	46-3/4"	IN48⊗ ⊠48	16	35 lbs	⊙
	5'	58-3/4"	IN48⊗ ⊠60	22	42 lbs	⊙
	6'	70-3/4"	IN48⊗ ⊠72	26	45 lbs	⊙
	7'	82-3/4"	IN48⊗ ⊠84	30	51 lbs	⊙
	8'	94-3/4"	IN48⊗ ⊠96	32	56 lbs	⊙
	9'	106-3/4"	IN48⊗ ⊠108	36	63 lbs	⊙
	10'	118-3/4"	IN48⊗ ⊠120	44	70 lbs	⊙
	11'	130-3/4"	IN48⊗ ⊠132	48	74 lbs	⊙
	12'	142-3/4"	IN48⊗ ⊠144	52	81 lbs	⊙
	13'	154-3/4"	IN48⊗ ⊠156	56	87 lbs	⊙
	14'	166-3/4"	IN48⊗ ⊠168	60	92 lbs	⊙
	15'	178-3/4"	IN48⊗ ⊠180	64	98 lbs	⊙
5' HEIGHT	3'	34-3/4"	IN60⊗ ⊠36	12	35 lbs	⊙
	4'	46-3/4"	IN60⊗ ⊠48	16	42 lbs	⊙
	5'	58-3/4"	IN60⊗ ⊠60	22	49 lbs	⊙
	6'	70-3/4"	IN60⊗ ⊠72	26	56 lbs	⊙
	7'	82-3/4"	IN60⊗ ⊠84	30	63 lbs	⊙
	8'	94-3/4"	IN60⊗ ⊠96	32	70 lbs	⊙
	9'	106-3/4"	IN60⊗ ⊠108	36	77 lbs	⊙
	10'	118-3/4"	IN60⊗ ⊠120	44	84 lbs	⊙
	11'	130-3/4"	IN60⊗ ⊠132	48	91 lbs	⊙
	12'	142-3/4"	IN60⊗ ⊠144	52	98 lbs	⊙
	13'	154-3/4"	IN60⊗ ⊠156	56	105 lbs	⊙
	14'	166-3/4"	IN60⊗ ⊠168	60	112 lbs	⊙
	15'	178-3/4"	IN60⊗ ⊠180	64	120 lbs	⊙

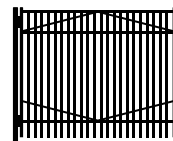

#402

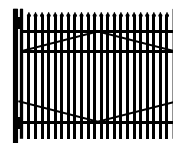

#401

⊗ = COLOR OPTIONS AVAILABLE | **B** = Black **Z** = Bronze **W** = White

⊠ = FENCE STYLES AVAILABLE | **402** = #402 **401** = #401

⊙ = NON-STOCKED PRODUCT

NOTE: Double Drive Gates consist of two gate leaves.
Gate leaf width greater than 60" will have a diagonal brace, not V brace.

Jerith Industrial

SWING GATES

3-RAIL SINGLE SWING GATES

STANDARD BOTTOM | GATE HARDWARE SOLD SEPARATELY

OPENING	LEAF WIDTH	ITEM NUMBER	PICKET QTY	WEIGHT	STOCKING
3'	34-3/4"	IN72⊗☒36	12	42 lbs	⊙
4'	46-3/4"	IN72⊗☒48	16	49 lbs	⊙
5'	58-3/4"	IN72⊗☒60	22	56 lbs	⊙
6'	70-3/4"	IN72⊗☒72	26	63 lbs	⊙
7'	82-3/4"	IN72⊗☒84	30	70 lbs	⊙
8'	94-3/4"	IN72⊗☒96	32	77 lbs	⊙
9'	106-3/4"	IN72⊗☒108	36	84 lbs	⊙
10'	118-3/4"	IN72⊗☒120	44	91 lbs	⊙
11'	130-3/4"	IN72⊗☒132	48	98 lbs	⊙
12'	142-3/4"	IN72⊗☒144	52	105 lbs	⊙

6'
HEIGHT

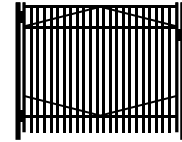

#402

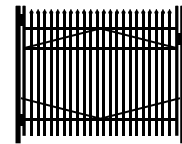

#401

⊗ = COLOR OPTIONS AVAILABLE | **B** = Black **Z** = Bronze **W** = White

☒ = FENCE STYLES AVAILABLE | **402** = #402 **401** = #401

⊙ = NON-STOCKED PRODUCT

NOTE: Double Drive Gates consist of two gate leaves.
Gate leaf width greater than 60" will have a diagonal brace, not V brace.

Jerith Industrial

SWING GATES

3-RAIL SINGLE SWING GATES

DROP BOTTOM | GATE HARDWARE SOLD SEPARATELY

OPENING	LEAF WIDTH	ITEM NUMBER	PICKET QTY	WEIGHT	STOCKING	
4' HEIGHT	3'	IN48⊗ ⊠36DB	12	28 lbs	⊙	
	4'	IN48⊗ ⊠48DB	16	35 lbs	⊙	
	5'	IN48⊗ ⊠60DB	22	42 lbs	⊙	
	6'	IN48⊗ ⊠72DB	26	45 lbs	⊙	
	7'	IN48⊗ ⊠84DB	30	51 lbs	⊙	
	8'	IN48⊗ ⊠96DB	32	56 lbs	⊙	
	9'	IN48⊗ ⊠108DB	36	63 lbs	⊙	
	10'	IN48⊗ ⊠120DB	44	70 lbs	⊙	
	11'	IN48⊗ ⊠132DB	48	74 lbs	⊙	
	12'	IN48⊗ ⊠144DB	52	81 lbs	⊙	
	13'	IN48⊗ ⊠156DB	56	87 lbs	⊙	
	14'	IN48⊗ ⊠168DB	60	92 lbs	⊙	
	15'	IN48⊗ ⊠180DB	64	98 lbs	⊙	
	5' HEIGHT	3'	IN60⊗ ⊠36DB	12	35 lbs	⊙
		4'	IN60⊗ ⊠48DB	16	42 lbs	⊙
5'		IN60⊗ ⊠60DB	22	49 lbs	⊙	
6'		IN60⊗ ⊠72DB	26	56 lbs	⊙	
7'		IN60⊗ ⊠84DB	30	63 lbs	⊙	
8'		IN60⊗ ⊠96DB	32	70 lbs	⊙	
9'		IN60⊗ ⊠108DB	36	77 lbs	⊙	
10'		IN60⊗ ⊠120DB	44	84 lbs	⊙	
11'		IN60⊗ ⊠132DB	48	91 lbs	⊙	
12'		IN60⊗ ⊠144DB	52	98 lbs	⊙	
13'		IN60⊗ ⊠156DB	56	105 lbs	⊙	
14'		IN60⊗ ⊠168DB	60	112 lbs	⊙	
15'		IN60⊗ ⊠180DB	64	120 lbs	⊙	

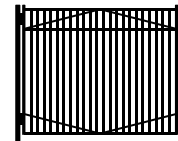

#402

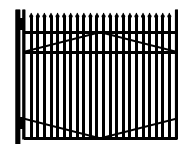

#401

⊗ = COLOR OPTIONS AVAILABLE | **B** = Black **Z** = Bronze **W** = White

⊠ = FENCE STYLES AVAILABLE | **402** = #402 **401** = #401

⊙ = NON-STOCKED PRODUCT

NOTE: Double Drive Gates consist of two gate leaves.
Gate leaf width greater than 60" will have a diagonal brace, not V brace.

Jerith Industrial

SWING GATES

3-RAIL SINGLE SWING GATES

DROP BOTTOM | GATE HARDWARE SOLD SEPARATELY

OPENING	LEAF WIDTH	ITEM NUMBER	PICKET QTY	WEIGHT	STOCKING
3'	34-3/4"	IN72⊗ ⊠36DB	12	42 lbs	⊙
4'	46-3/4"	IN72⊗ ⊠48DB	16	49 lbs	⊙
5'	58-3/4"	IN72⊗ ⊠60DB	22	56 lbs	⊙
6'	70-3/4"	IN72⊗ ⊠72DB	26	63 lbs	⊙
7'	82-3/4"	IN72⊗ ⊠84DB	30	70 lbs	⊙
8'	94-3/4"	IN72⊗ ⊠96DB	32	77 lbs	⊙
9'	106-3/4"	IN72⊗ ⊠108DB	36	84 lbs	⊙
10'	118-3/4"	IN72⊗ ⊠120DB	44	91 lbs	⊙
11'	130-3/4"	IN72⊗ ⊠132DB	48	98 lbs	⊙
12'	142-3/4"	IN72⊗ ⊠144DB	52	105 lbs	⊙

6'
HEIGHT

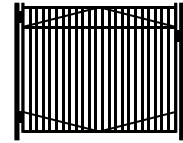

#402

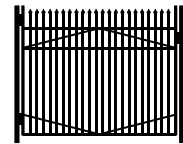

#401

⊗ = COLOR OPTIONS AVAILABLE | **B** = Black **Z** = Bronze **W** = White

⊠ = FENCE STYLES AVAILABLE | **402** = #402 **401** = #401

⊙ = NON-STOCKED PRODUCT

NOTE: Double Drive Gates consist of two gate leaves.
Gate leaf width greater than 60" will have a diagonal brace, not V brace.

Jerith Industrial

SWING GATES

4-RAIL SINGLE SWING GATES

STANDARD BOTTOM | GATE HARDWARE SOLD SEPARATELY

	OPENING	LEAF WIDTH	ITEM NUMBER	PICKET QTY	WEIGHT	STOCKING
7' HEIGHT	3'	34-3/4"	IN84⊗☒36	6	49 lbs	⊙
	4'	46-3/4"	IN84⊗☒48	8	56 lbs	⊙
	5'	58-3/4"	IN84⊗☒60	11	63 lbs	⊙
	6'	70-3/4"	IN84⊗☒72	13	70 lbs	⊙
	7'	82-3/4"	IN84⊗☒84	15	77 lbs	⊙
	8'	94-3/4"	IN84⊗☒96	16	84 lbs	⊙
	9'	106-3/4"	IN84⊗☒108	18	91 lbs	⊙
	10'	118-3/4"	IN84⊗☒120	22	98 lbs	⊙
	11'	130-3/4"	IN84⊗☒132	24	105 lbs	⊙
	12'	142-3/4"	IN84⊗☒144	26	112 lbs	⊙
8' HEIGHT	3'	34-3/4"	IN96⊗☒36	6	56 lbs	⊙
	4'	46-3/4"	IN96⊗☒48	8	63 lbs	⊙
	5'	58-3/4"	IN96⊗☒60	11	70 lbs	⊙
	6'	70-3/4"	IN96⊗☒72	13	77 lbs	⊙
	7'	82-3/4"	IN96⊗☒84	16	84 lbs	⊙
	8'	94-3/4"	IN96⊗☒96	16	91 lbs	⊙
	9'	106-3/4"	IN96⊗☒108	18	98 lbs	⊙
	10'	118-3/4"	IN96⊗☒120	22	105 lbs	⊙
	11'	130-3/4"	IN96⊗☒132	24	112 lbs	⊙
	12'	142-3/4"	IN96⊗☒144	26	119 lbs	⊙

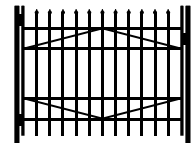

#101

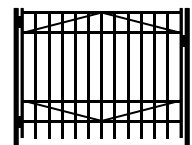

#202

⊗ = COLOR OPTIONS AVAILABLE | **B** = Black **Z** = Bronze **W** = White

☒ = FENCE STYLES AVAILABLE | **101** = #101 **202** = #202

⊙ = NON-STOCKED PRODUCT

NOTE: Double Drive Gates consist of two gate leaves.
Gate leaf width greater than 60" will have a diagonal brace, not V brace.

Jerith Industrial

SWING GATES

4-RAIL SINGLE SWING GATES

DROP BOTTOM | GATE HARDWARE SOLD SEPARATELY

	OPENING	LEAF WIDTH	ITEM NUMBER	PICKET QTY	WEIGHT	STOCKING	
7' HEIGHT	3'	34-3/4"	IN84⊗ ⊠36DB	6	49 lbs	⊙	
	4'	46-3/4"	IN84⊗ ⊠48DB	8	56 lbs	⊙	
	5'	58-3/4"	IN84⊗ ⊠60DB	11	63 lbs	⊙	
	6'	70-3/4"	IN84⊗ ⊠72DB	13	70 lbs	⊙	
	7'	82-3/4"	IN84⊗ ⊠84DB	15	77 lbs	⊙	
	8'	94-3/4"	IN84⊗ ⊠96DB	16	84 lbs	⊙	
	9'	106-3/4"	IN84⊗ ⊠108DB	18	91 lbs	⊙	
	10'	118-3/4"	IN84⊗ ⊠120DB	22	98 lbs	⊙	
	11'	130-3/4"	IN84⊗ ⊠132DB	24	105 lbs	⊙	
	12'	142-3/4"	IN84⊗ ⊠144DB	26	112 lbs	⊙	
	8' HEIGHT	3'	34-3/4"	IN96⊗ ⊠36DB	6	56 lbs	⊙
		4'	46-3/4"	IN96⊗ ⊠48DB	8	63 lbs	⊙
5'		58-3/4"	IN96⊗ ⊠60DB	11	70 lbs	⊙	
6'		70-3/4"	IN96⊗ ⊠72DB	13	77 lbs	⊙	
7'		82-3/4"	IN96⊗ ⊠84DB	16	84 lbs	⊙	
8'		94-3/4"	IN96⊗ ⊠96DB	16	91 lbs	⊙	
9'		106-3/4"	IN96⊗ ⊠108DB	18	98 lbs	⊙	
10'		118-3/4"	IN96⊗ ⊠120DB	22	105 lbs	⊙	
11'		130-3/4"	IN96⊗ ⊠132DB	24	112 lbs	⊙	
12'		142-3/4"	IN96⊗ ⊠144DB	26	119 lbs	⊙	

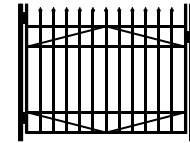

#101

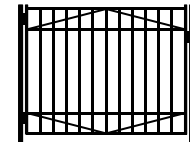

#202

⊗ = COLOR OPTIONS AVAILABLE | **B** = Black **Z** = Bronze **W** = White

⊠ = FENCE STYLES AVAILABLE | **101** = #101 **202** = #202

⊙ = NON-STOCKED PRODUCT

NOTE: Double Drive Gates consist of two gate leaves.
Gate leaf width greater than 60" will have a diagonal brace, not V brace.

Jerith Industrial

SWING GATES

4-RAIL SINGLE SWING GATES

STANDARD BOTTOM | GATE HARDWARE SOLD SEPARATELY

	OPENING	LEAF WIDTH	ITEM NUMBER	PICKET QTY	WEIGHT	STOCKING
7' HEIGHT	3'	34-3/4"	IN84⊗ ⊠36	12	56 lbs	⊙
	4'	46-3/4"	IN84⊗ ⊠48	16	63 lbs	⊙
	5'	58-3/4"	IN84⊗ ⊠60	22	70 lbs	⊙
	6'	70-3/4"	IN84⊗ ⊠72	26	77 lbs	⊙
	7'	82-3/4"	IN84⊗ ⊠84	30	84 lbs	⊙
	8'	94-3/4"	IN84⊗ ⊠96	32	91 lbs	⊙
8' HEIGHT	9'	106-3/4"	IN84⊗ ⊠108	36	98 lbs	⊙
	3'	34-3/4"	IN96⊗ ⊠36	12	64 lbs	⊙
	4'	46-3/4"	IN96⊗ ⊠48	16	71 lbs	⊙
	5'	58-3/4"	IN96⊗ ⊠60	22	78 lbs	⊙
	6'	70-3/4"	IN96⊗ ⊠72	26	85 lbs	⊙
	7'	82-3/4"	IN96⊗ ⊠84	30	92 lbs	⊙
	8'	94-3/4"	IN96⊗ ⊠96	32	99 lbs	⊙
	9'	106-3/4"	IN96⊗ ⊠108	36	106 lbs	⊙

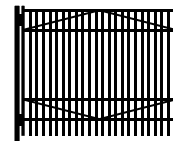

#402

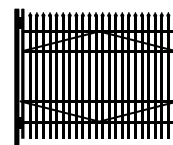

#401

⊗ = COLOR OPTIONS AVAILABLE | **B** = Black **Z** = Bronze **W** = White

⊠ = FENCE STYLES AVAILABLE | **402** = #402 **401** = #401

⊙ = NON-STOCKED PRODUCT

NOTE: Double Drive Gates consist of two gate leaves.

Gate leaf width greater than 60" will have a diagonal brace, not V brace.

Jerith Industrial

SWING GATES

4-RAIL SINGLE SWING GATES

DROP BOTTOM | GATE HARDWARE SOLD SEPARATELY

	OPENING	LEAF WIDTH	ITEM NUMBER	PICKET QTY	WEIGHT	STOCKING
7' HEIGHT	3'	34-3/4"	IN84⊗ ⊠36DB	12	56 lbs	⊙
	4'	46-3/4"	IN84⊗ ⊠48DB	16	63 lbs	⊙
	5'	58-3/4"	IN84⊗ ⊠60DB	22	70 lbs	⊙
	6'	70-3/4"	IN84⊗ ⊠72DB	26	77 lbs	⊙
	7'	82-3/4"	IN84⊗ ⊠84DB	30	84 lbs	⊙
	8'	94-3/4"	IN84⊗ ⊠96DB	32	91 lbs	⊙
8' HEIGHT	9'	106-3/4"	IN84⊗ ⊠108DB	36	98 lbs	⊙
	3'	34-3/4"	IN96⊗ ⊠36DB	12	64 lbs	⊙
	4'	46-3/4"	IN96⊗ ⊠48DB	16	71 lbs	⊙
	5'	58-3/4"	IN96⊗ ⊠60DB	22	78 lbs	⊙
	6'	70-3/4"	IN96⊗ ⊠72DB	26	85 lbs	⊙
	7'	82-3/4"	IN96⊗ ⊠84DB	30	92 lbs	⊙
	8'	94-3/4"	IN96⊗ ⊠96DB	32	99 lbs	⊙
	9'	106-3/4"	IN96⊗ ⊠108DB	36	106 lbs	⊙

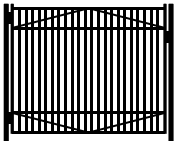

#402

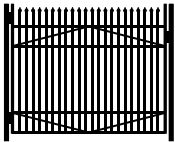

#401

⊗ = COLOR OPTIONS AVAILABLE | **B** = Black **Z** = Bronze **W** = White

⊠ = FENCE STYLES AVAILABLE | **402** = #402 **401** = #401

⊙ = NON-STOCKED PRODUCT

NOTE: Double Drive Gates consist of two gate leaves.

Gate leaf width greater than 60" will have a diagonal brace, not V brace.

Jerith Industrial

ACCENT GATES

ACCENT GATE SPECIFICATIONS

2" sq. x .125" wall GATE ENDS | 1-5/8" x 1-5/8" (.100" side/.070" top) RAILS | 1" sq. x .062" wall PICKETS

**ACCENT GATE
DIMENSIONAL DRAWING**



**ACCENT GATE
HARDWARE & POST
INTERSPACES**

OPENING	LEAF WIDTH*	HC	LC	P _S
3'	34-3/4"	1/2"	3/4"	36"
4'	46-3/4"	1/2"	3/4"	48"
5'	58-3/4"	1/2"	3/4"	60"
6'	70-3/4"	1/2"	3/4"	72"

W = width*

HC = hinge clearance

LC = latch clearance

P_S = gate post spacing**

** From inside to inside

*Gate Hardware sold separately.
See Gate Hardware section for specific details.*

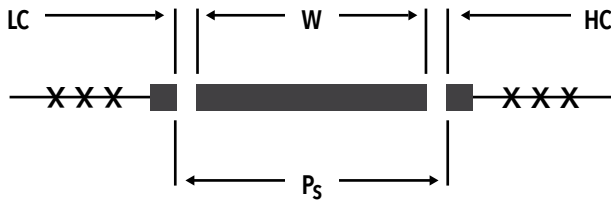

Jerith Industrial

ACCENT GATES

3-RAIL ACCENT GATES

STANDARD BOTTOM | GATE HARDWARE SOLD SEPARATELY

	OPENING	LEAF WIDTH	ITEM NUMBER	PICKET QTY	WEIGHT	STOCKING
4' HEIGHT	3'	34-3/4"	IN48⊗ ⊠36AG	6	21 lbs	⊙
	4'	46-3/4"	IN48⊗ ⊠48AG	8	28 lbs	⊙
	5'	58-3/4"	IN48⊗ ⊠60AG	11	33 lbs	⊙
	6'	70-3/4"	IN48⊗ ⊠72AG	13	38 lbs	⊙
5' HEIGHT	3'	34-3/4"	IN60⊗ ⊠36AG	6	25 lbs	⊙
	4'	46-3/4"	IN60⊗ ⊠48AG	8	32 lbs	⊙
	5'	58-3/4"	IN60⊗ ⊠60AG	11	37 lbs	⊙
	6'	70-3/4"	IN60⊗ ⊠72AG	13	42 lbs	⊙
6' HEIGHT	3'	34-3/4"	IN72⊗ ⊠36AG	6	30 lbs	⊙
	4'	46-3/4"	IN72⊗ ⊠48AG	8	37 lbs	⊙
	5'	58-3/4"	IN72⊗ ⊠60AG	11	44 lbs	⊙
	6'	70-3/4"	IN72⊗ ⊠72AG	13	51 lbs	⊙

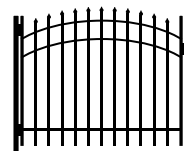

#101

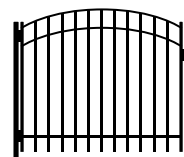

#202

⊗ = COLOR OPTIONS AVAILABLE | **B** = Black **Z** = Bronze **W** = White

⊠ = FENCE STYLES AVAILABLE | **101** = #101 **202** = #202

⊙ = NON-STOCKED PRODUCT

NOTE: Double Drive Gates consist of two gate leafs

Jerith Industrial

ACCENT GATES

3-RAIL ACCENT GATES

DROP BOTTOM | GATE HARDWARE SOLD SEPARATELY

	OPENING	LEAF WIDTH	ITEM NUMBER	PICKET QTY	WEIGHT	STOCKING
4' HEIGHT	3'	34-3/4"	IN48⊗ ⊠36AGDB	6	21 lbs	⊙
	4'	46-3/4"	IN48⊗ ⊠48AGDB	8	28 lbs	⊙
	5'	58-3/4"	IN48⊗ ⊠60AGDB	11	33 lbs	⊙
	6'	70-3/4"	IN48⊗ ⊠72AGDB	13	38 lbs	⊙
5' HEIGHT	3'	34-3/4"	IN60⊗ ⊠36AGDB	6	25 lbs	⊙
	4'	46-3/4"	IN60⊗ ⊠48AGDB	8	32 lbs	⊙
	5'	58-3/4"	IN60⊗ ⊠60AGDB	11	37 lbs	⊙
	6'	70-3/4"	IN60⊗ ⊠72AGDB	13	42 lbs	⊙
6' HEIGHT	3'	34-3/4"	IN72⊗ ⊠36AGDB	6	30 lbs	⊙
	4'	46-3/4"	IN72⊗ ⊠48AGDB	8	37 lbs	⊙
	5'	58-3/4"	IN72⊗ ⊠60AGDB	11	44 lbs	⊙
	6'	70-3/4"	IN72⊗ ⊠72AGDB	13	51 lbs	⊙

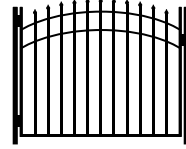

#101

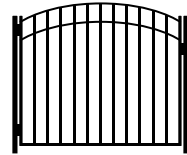

#202

⊗ = COLOR OPTIONS AVAILABLE | **B** = Black **Z** = Bronze **W** = White

⊠ = FENCE STYLES AVAILABLE | **101** = #101 **202** = #202

⊙ = NON-STOCKED PRODUCT

NOTE: Double Drive Gates consist of two gate leaves

Jerith Industrial

ACCENT GATES

3-RAIL ACCENT GATES

STANDARD BOTTOM | GATE HARDWARE SOLD SEPARATELY

	OPENING	LEAF WIDTH	ITEM NUMBER	PICKET QTY	WEIGHT	STOCKING
4' HEIGHT	3'	34-3/4"	IN48⊗ ⊠36AG	12	28 lbs	⊙
	4'	46-3/4"	IN48⊗ ⊠48AG	16	35 lbs	⊙
	5'	58-3/4"	IN48⊗ ⊠60AG	22	42 lbs	⊙
	6'	70-3/4"	IN48⊗ ⊠72AG	26	45 lbs	⊙
5' HEIGHT	3'	34-3/4"	IN60⊗ ⊠36AG	12	35 lbs	⊙
	4'	46-3/4"	IN60⊗ ⊠48AG	16	42 lbs	⊙
	5'	58-3/4"	IN60⊗ ⊠60AG	22	49 lbs	⊙
	6'	70-3/4"	IN60⊗ ⊠72AG	26	56 lbs	⊙

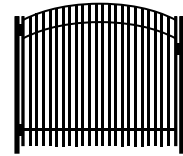

#402

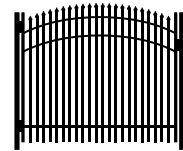

#401

⊗ = COLOR OPTIONS AVAILABLE | **B** = Black **Z** = Bronze **W** = White

⊠ = FENCE STYLES AVAILABLE | **402** = #402 **401** = #401

⊙ = NON-STOCKED PRODUCT

NOTE: Double Drive Gates consist of two gate leaves

Jerith Industrial

ACCENT GATES

3-RAIL ACCENT GATES

DROP BOTTOM | GATE HARDWARE SOLD SEPARATELY

	OPENING	LEAF WIDTH	ITEM NUMBER	PICKET QTY	WEIGHT	STOCKING
4' HEIGHT	3'	34-3/4"	IN48⊗ ⊠36AGDB	12	28 lbs	⊙
	4'	46-3/4"	IN48⊗ ⊠48AGDB	16	35 lbs	⊙
	5'	58-3/4"	IN48⊗ ⊠60AGDB	22	42 lbs	⊙
	6'	70-3/4"	IN48⊗ ⊠72AGDB	26	45 lbs	⊙
5' HEIGHT	3'	34-3/4"	IN60⊗ ⊠36AGDB	12	35 lbs	⊙
	4'	46-3/4"	IN60⊗ ⊠48AGDB	16	42 lbs	⊙
	5'	58-3/4"	IN60⊗ ⊠60AGDB	22	49 lbs	⊙
	6'	70-3/4"	IN60⊗ ⊠72AGDB	26	56 lbs	⊙

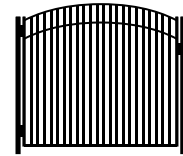

#402

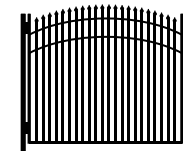

#401

⊗ = COLOR OPTIONS AVAILABLE | **B** = Black **Z** = Bronze **W** = White

⊠ = FENCE STYLES AVAILABLE | **402** = #402 **401** = #401

⊙ = NON-STOCKED PRODUCT

NOTE: Double Drive Gates consist of two gate leaves

Jerith Industrial

RAINBOW GATES

RAINBOW GATE SPECIFICATIONS

2" sq. x .125" wall GATE ENDS | 1-5/8" x 1-5/8" (.100" side/.070" top) RAILS | 1" sq. x .062" wall PICKETS

**RAINBOW GATE
DIMENSIONAL DRAWING**

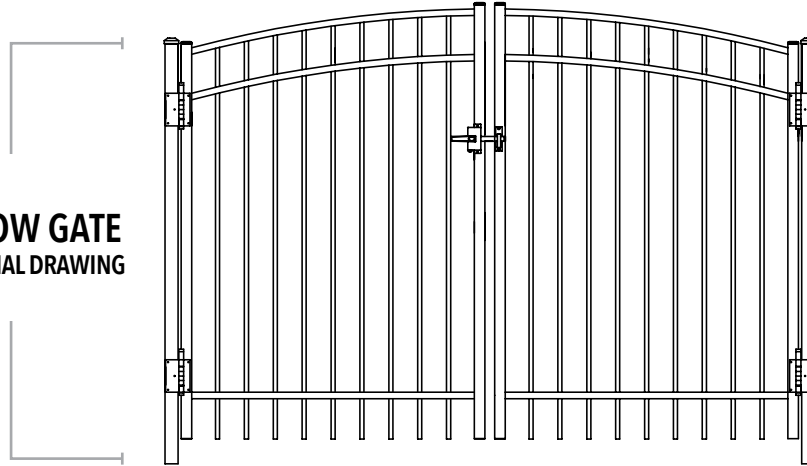

Style #202 Shown

NOTE: Double Drive Gates consist of two gate leaves

**RAINBOW GATE
HARDWARE & POST
INTERSPACES**

OPENING	LEAF WIDTH*	HC	LC	P _d
6'	34-3/4"	1/2"	3/4"	36"
8'	46-3/4"	1/2"	3/4"	48"
10'	58-3/4"	1/2"	3/4"	60"
12'	70-3/4"	1/2"	3/4"	72"

W = width*

HC = hinge clearance

LC = latch clearance

P_d = gate post spacing**

** From inside to inside

*Gate Hardware sold separately.
See Gate Hardware section for specific details.*

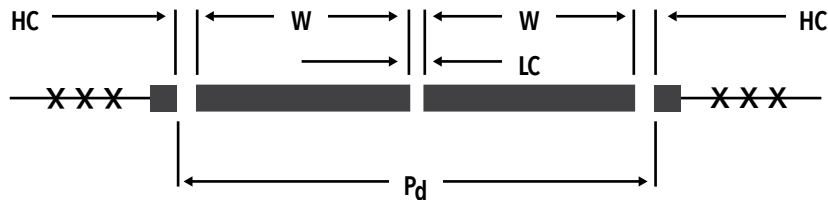

Jerith Industrial

RAINBOW GATES

3-RAIL RAINBOW GATES

STANDARD BOTTOM | GATE HARDWARE SOLD SEPARATELY

	OPENING	LEAF WIDTH	ITEM NUMBER	PICKET QTY	WEIGHT	STOCKING
4' HEIGHT	3'	34-3/4"	IN48⊗ ⊠36AGR	6	21 lbs	⊙
	4'	46-3/4"	IN48⊗ ⊠48AGR	8	28 lbs	⊙
	5'	58-3/4"	IN48⊗ ⊠60AGR	11	33 lbs	⊙
	6'	70-3/4"	IN48⊗ ⊠72AGR	13	38 lbs	⊙
5' HEIGHT	3'	34-3/4"	IN60⊗ ⊠36AGR	6	25 lbs	⊙
	4'	46-3/4"	IN60⊗ ⊠48AGR	8	32 lbs	⊙
	5'	58-3/4"	IN60⊗ ⊠60AGR	11	37 lbs	⊙
	6'	70-3/4"	IN60⊗ ⊠72AGR	13	42 lbs	⊙
6' HEIGHT	3'	34-3/4"	IN72⊗ ⊠36AGR	6	30 lbs	⊙
	4'	46-3/4"	IN72⊗ ⊠48AGR	8	37 lbs	⊙
	5'	58-3/4"	IN72⊗ ⊠60AGR	11	44 lbs	⊙
	6'	70-3/4"	IN72⊗ ⊠72AGR	13	51 lbs	⊙

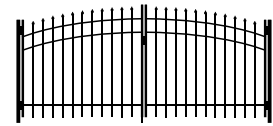

#101



#202

⊗ = COLOR OPTIONS AVAILABLE | **B** = Black **Z** = Bronze **W** = White

⊠ = FENCE STYLES AVAILABLE | **101** = #101 **202** = #202

⊙ = NON-STOCKED PRODUCT

NOTE: Double Drive Gates consist of two gate leafs

Jerith Industrial

RAINBOW GATES

3-RAIL RAINBOW GATES

DROP BOTTOM | GATE HARDWARE SOLD SEPARATELY

	OPENING	LEAF WIDTH	ITEM NUMBER	PICKET QTY	WEIGHT	STOCKING
4' HEIGHT	3'	34-3/4"	IN48⊗ ⊠36AGRDB	6	21 lbs	⊙
	4'	46-3/4"	IN48⊗ ⊠48AGRDB	8	28 lbs	⊙
	5'	58-3/4"	IN48⊗ ⊠60AGRDB	11	33 lbs	⊙
	6'	70-3/4"	IN48⊗ ⊠72AGRDB	13	38 lbs	⊙
5' HEIGHT	3'	34-3/4"	IN60⊗ ⊠36AGRDB	6	25 lbs	⊙
	4'	46-3/4"	IN60⊗ ⊠48AGRDB	8	32 lbs	⊙
	5'	58-3/4"	IN60⊗ ⊠60AGRDB	11	37 lbs	⊙
	6'	70-3/4"	IN60⊗ ⊠72AGRDB	13	42 lbs	⊙
6' HEIGHT	3'	34-3/4"	IN72⊗ ⊠36AGRDB	6	30 lbs	⊙
	4'	46-3/4"	IN72⊗ ⊠48AGRDB	8	37 lbs	⊙
	5'	58-3/4"	IN72⊗ ⊠60AGRDB	11	44 lbs	⊙
	6'	70-3/4"	IN72⊗ ⊠72AGRDB	13	51 lbs	⊙

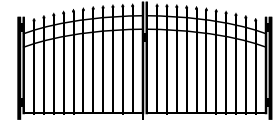

#101

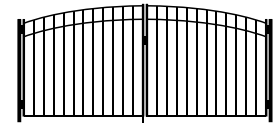

#202

⊗ = COLOR OPTIONS AVAILABLE | **B** = Black **Z** = Bronze **W** = White

⊠ = FENCE STYLES AVAILABLE | **101** = #101 **202** = #202

⊙ = NON-STOCKED PRODUCT

NOTE: Double Drive Gates consist of two gate leaves

Jerith Industrial

RAINBOW GATES

3-RAIL RAINBOW GATES

STANDARD BOTTOM | GATE HARDWARE SOLD SEPARATELY

	OPENING	LEAF WIDTH	ITEM NUMBER	PICKET QTY	WEIGHT	STOCKING
4' HEIGHT	3'	34-3/4"	IN48⊗ ⊠36AGR	12	28 lbs	⊙
	4'	46-3/4"	IN48⊗ ⊠48AGR	16	35 lbs	⊙
	5'	58-3/4"	IN48⊗ ⊠60AGR	22	42 lbs	⊙
	6'	70-3/4"	IN48⊗ ⊠72AGR	26	45 lbs	⊙
5' HEIGHT	3'	34-3/4"	IN60⊗ ⊠36AGR	12	35 lbs	⊙
	4'	46-3/4"	IN60⊗ ⊠48AGR	16	42 lbs	⊙
	5'	58-3/4"	IN60⊗ ⊠60AGR	22	49 lbs	⊙
	6'	70-3/4"	IN60⊗ ⊠72AGR	26	56 lbs	⊙

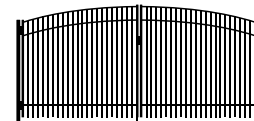

#402

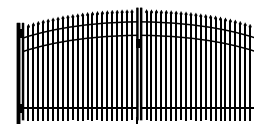

#401

⊗ = COLOR OPTIONS AVAILABLE | **B** = Black **Z** = Bronze **W** = White

⊠ = FENCE STYLES AVAILABLE | **402** = #402 **401** = #401

⊙ = NON-STOCKED PRODUCT

NOTE: Double Drive Gates consist of two gate leaves

Jerith Industrial

RAINBOW GATES

3-RAIL RAINBOW GATES

DROP BOTTOM | GATE HARDWARE SOLD SEPARATELY

	OPENING	LEAF WIDTH	ITEM NUMBER	PICKET QTY	WEIGHT	STOCKING
4' HEIGHT	3'	34-3/4"	IN48⊗ <u>☒</u> 36AGDB	12	28 lbs	⊙
	4'	46-3/4"	IN48⊗ <u>☒</u> 48AGDB	16	35 lbs	⊙
	5'	58-3/4"	IN48⊗ <u>☒</u> 60AGDB	22	42 lbs	⊙
	6'	70-3/4"	IN48⊗ <u>☒</u> 72AGDB	26	45 lbs	⊙
5' HEIGHT	3'	34-3/4"	IN60⊗ <u>☒</u> 36AGDB	12	35 lbs	⊙
	4'	46-3/4"	IN60⊗ <u>☒</u> 48AGDB	16	42 lbs	⊙
	5'	58-3/4"	IN60⊗ <u>☒</u> 60AGDB	22	49 lbs	⊙
	6'	70-3/4"	IN60⊗ <u>☒</u> 72AGDB	26	56 lbs	⊙

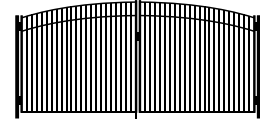

#402

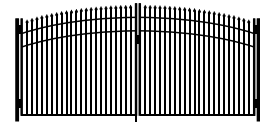

#401

⊗ = COLOR OPTIONS AVAILABLE | **B** = Black **Z** = Bronze **W** = White

☒ = FENCE STYLES AVAILABLE | **402** = #402 **401** = #401

⊙ = NON-STOCKED PRODUCT

NOTE: Double Drive Gates consist of two gate leaves

Jerith Industrial

ARCHED ESTATE GATES

ARCHED ESTATE GATE SPECIFICATIONS

2" sq. x .125" wall GATE ENDS | 1-5/8" x 1-5/8" (.100" side/.070" top) RAILS | 1" sq. x .062" wall PICKETS

ARCHED
ESTATE GATE
DIMENSIONAL DRAWING

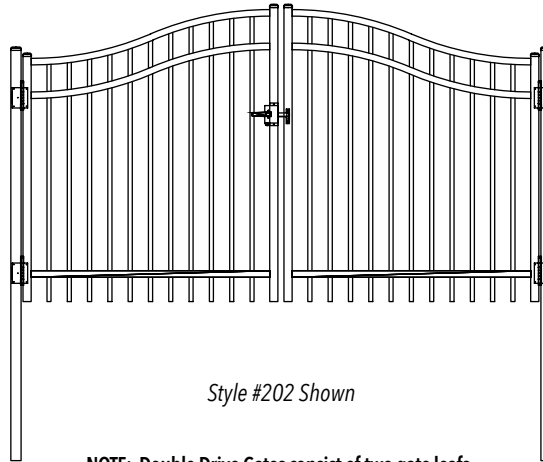

ARCHED
ESTATE GATE
HARDWARE & POST
INTERSPACES

OPENING	LEAF WIDTH*	HC	LC	P _d
12'	70-3/4"	1/2"	3/4"	72"
14'	82-3/4"	1/2"	3/4"	84"
16'	94-3/4"	1/2"	3/4"	96"
18'	106-3/4"	1/2"	3/4"	108"
20'	118-3/4"	1/2"	3/4"	120"

W = width* LC = latch clearance
HC = hinge clearance Pd = gate post spacing**

** From inside to inside

Gate Hardware sold separately.
See Gate Hardware section for specific details.

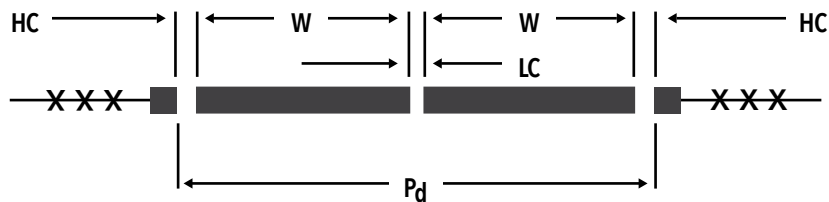

Jerith Industrial

ARCHED ESTATE GATES

3-RAIL ARCHED ESTATE GATES

STANDARD BOTTOM | GATE HARDWARE SOLD SEPARATELY

	OPENING	LEAF WIDTH	ITEM NUMBER	PICKET QTY	WEIGHT	STOCKING
3'-4' HEIGHT	12'	70-3/4"	IN36⊗ ⊠12EG	26	68 lbs	⊙
	14'	82-3/4"	IN36⊗ ⊠14EG	30	80 lbs	⊙
	16'	94-3/4"	IN36⊗ ⊠16EG	32	92 lbs	⊙
	18'	106-3/4"	IN36⊗ ⊠18EG	36	104 lbs	⊙
4'-5' HEIGHT	12'	70-3/4"	IN48⊗ ⊠12EG	26	90 lbs	⊙
	14'	82-3/4"	IN48⊗ ⊠14EG	30	102 lbs	⊙
	16'	94-3/4"	IN48⊗ ⊠16EG	32	114 lbs	⊙
	18'	106-3/4"	IN48⊗ ⊠18EG	36	126 lbs	⊙
5'-6' HEIGHT	12'	70-3/4"	IN60⊗ ⊠12EG	26	114 lbs	⊙
	14'	82-3/4"	IN60⊗ ⊠14EG	30	128 lbs	⊙
	16'	94-3/4"	IN60⊗ ⊠16EG	32	142 lbs	⊙
	18'	106-3/4"	IN60⊗ ⊠18EG	36	156 lbs	⊙
6'-7' HEIGHT	12'	70-3/4"	IN72⊗ ⊠12EG	26	140 lbs	⊙
	14'	82-3/4"	IN72⊗ ⊠14EG	30	154 lbs	⊙
	16'	94-3/4"	IN72⊗ ⊠16EG	32	168 lbs	⊙
	18'	106-3/4"	IN72⊗ ⊠18EG	36	182 lbs	⊙
	20'	118-3/4"	IN72⊗ ⊠20EG	44	196 lbs	⊙

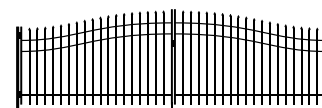

#101



#202

⊗ = COLOR OPTIONS AVAILABLE | **B** = Black **Z** = Bronze **W** = White

⊠ = FENCE STYLES AVAILABLE | **101** = #101 **202** = #202

⊙ = NON-STOCKED PRODUCT

NOTE: Double Drive Gates consist of two gate leaves

Jerith Industrial

ARCHED ESTATE GATES

3-RAIL ARCHED ESTATE GATES

DROP BOTTOM | GATE HARDWARE SOLD SEPARATELY

	OPENING	LEAF WIDTH	ITEM NUMBER	PICKET QTY	WEIGHT	STOCKING
3'-4' HEIGHT	12'	70-3/4"	IN36⊗ ⊠12EGDB	26	68 lbs	⊙
	14'	82-3/4"	IN36⊗ ⊠14EGDB	30	80 lbs	⊙
	16'	94-3/4"	IN36⊗ ⊠16EGDB	32	92 lbs	⊙
	18'	106-3/4"	IN36⊗ ⊠18EGDB	36	104 lbs	⊙
	20'	118-3/4"	IN36⊗ ⊠20EGDB	44	116 lbs	⊙
4'-5' HEIGHT	12'	70-3/4"	IN48⊗ ⊠12EGDB	26	90 lbs	⊙
	14'	82-3/4"	IN48⊗ ⊠14EGDB	30	102 lbs	⊙
	16'	94-3/4"	IN48⊗ ⊠16EGDB	32	114 lbs	⊙
	18'	106-3/4"	IN48⊗ ⊠18EGDB	36	126 lbs	⊙
	20'	118-3/4"	IN48⊗ ⊠20EGDB	44	138 lbs	⊙
5'-6' HEIGHT	12'	70-3/4"	IN60⊗ ⊠12EGDB	26	114 lbs	⊙
	14'	82-3/4"	IN60⊗ ⊠14EGDB	30	128 lbs	⊙
	16'	94-3/4"	IN60⊗ ⊠16EGDB	32	142 lbs	⊙
	18'	106-3/4"	IN60⊗ ⊠18EGDB	36	156 lbs	⊙
	20'	118-3/4"	IN60⊗ ⊠20EGDB	44	170 lbs	⊙
6'-7' HEIGHT	12'	70-3/4"	IN72⊗ ⊠12EGDB	26	140 lbs	⊙
	14'	82-3/4"	IN72⊗ ⊠14EGDB	30	154 lbs	⊙
	16'	94-3/4"	IN72⊗ ⊠16EGDB	32	168 lbs	⊙
	18'	106-3/4"	IN72⊗ ⊠18EGDB	36	182 lbs	⊙
	20'	118-3/4"	IN72⊗ ⊠20EGDB	44	196 lbs	⊙

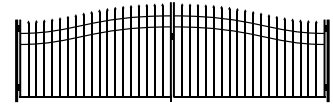

#101



#202

⊗ = COLOR OPTIONS AVAILABLE | **B** = Black **Z** = Bronze **W** = White

⊠ = FENCE STYLES AVAILABLE | **101** = #101 **202** = #202

⊙ = NON-STOCKED PRODUCT

NOTE: Double Drive Gates consist of two gate leaves

Jerith Industrial

GATE HARDWARE

HARDWARE KITS

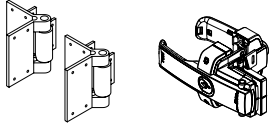

DESCRIPTION	HC	LC	ITEM NUMBER	QTY	BOX WT.
Single Gate Hardware Kit	1/2"	3/4"	KIN⊗SNGI	1	6 lbs

Kit includes: (2) ea. #IN⊗HIN | (1) ea. #BLLM

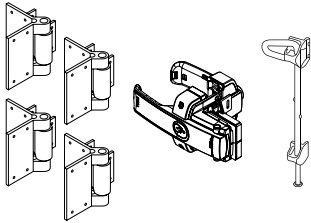

Double Gate Hardware Kit	1/2"	3/4"	KIN⊗DBLI-S	1	12 lbs
	1/2"	3/4"	KIN⊗DBLI-L	1	12.25 lbs

KIN⊗BDLI-S Kit includes: (4) ea. #IN⊗HIN | (1) ea. #BLLM | (1) ea. #BDRKS

KIN⊗BDLI-L Kit Includes: (4) ea. #IN⊗HIN | (1) ea. #BLLM | (1) ea. #BDRKL

⊗ = COLOR OPTIONS AVAILABLE | **B** = Black **Z** = Bronze **W** = White

Jerith Industrial

GATE HARDWARE

D & D GATE HARDWARE



D & D TRU CLOSE HINGE

Aluminum

HINGE CLEARANCE	ITEM NUMBER	COLOR	QTY	WT. EACH
13/16"	BTCRHIN	BLACK	1	.75 lbs

With 2 legs and screws

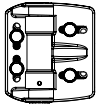

D & D ADJUSTABLE TRU CLOSE HINGE

Aluminum

ADJUSTABLE 7/8" - 2"	BTCAHIN	BLACK	1	1.2 lbs
----------------------	---------	-------	---	---------



D & D MAGNA LATCH VERTICAL PULL (SHORT)

Aluminum

ADJUSTABLE	BMLS	BLACK	1	1.8 lbs
------------	------	-------	---	---------



D & D MAGNA LATCH TOP PULL

ADJUSTABLE 7/8" - 2"	BML	BLACK	1	1.2 lbs
----------------------	-----	-------	---	---------



D & D MAGNA LATCH WITH ALERT

ADJUSTABLE	BMLA	BLACK	1	2 lbs
------------	------	-------	---	-------

Jerith Industrial

GATE HARDWARE

D & D GATE HARDWARE

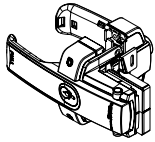

**D & D
LOKKLATCH
MAGNETIC**

HINGE CLEARANCE	ITEM NUMBER	COLOR	QTY	WT. EACH
3/4"	BLLM	BLACK	1	2 lbs

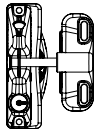

**D & D
LOKKLATCH
WITH EXTERNAL
ACCESS**

1/2"	BLLAAB	BLACK	1	1 lb
------	--------	-------	---	------

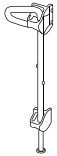

**D & D
DROP ROD KIT**

LENGTH	ITEM NUMBER	COLOR	QTY	WT. EACH
24"	BDRKS	BLACK	1	2 lbs

Jerith Industrial

GATE HARDWARE

GATE HARDWARE

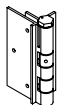

SELF CLOSING HINGE
Aluminum

HINGE CLEARANCE	ITEM NUMBER	QTY	WT. EACH
1/2"	RS⊗HIN	1	.75 lbs

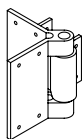

INDUSTRIAL HINGE
Aluminum

1/2"	IN⊗HIN	1	2 lbs
------	--------	---	-------

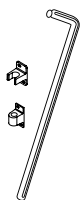

DROP ROD KIT
Aluminum

LENGTH	ITEM NUMBER	QTY	WT. EACH
30"	⊗DRKS	1	2 lbs
48"	⊗DRKL	1	2.25 lbs

⊗ = COLOR OPTIONS AVAILABLE | **B** = Black **Z** = Bronze **W** = White